

BKB



BM MAKİNA GRUP

ALUBKB

www.bmmakina.com.tr

BM MAKİNA Sanayi ve Ticaret A.Ş. 1999 yılında İstanbul'da kuruldu ve faaliyetlerine Perpa İstanbul ofisinde enerji ve data iletim sistemleri üreticisi VAHLE - Almanya ile elektrikli zincirli vinç üreticisi LIFTKET - Almanya firmalarının Türkiye genel temsilcisi ve distribütörü olarak başladı.

Sunduğu kaliteli hizmet ve ürünlerle kısa sürede pazarda yerini sağlamlaştıran BM MAKİNA, müşterilerinden gelen talepleri değerlendirerek 2002 yılında İstanbul Dudullu OSB içinde yer alan DES Sanayi Sitesinde bir üretim tesisi kurarak faaliyete geçirdi. 2003 yılında ise BKB markası altında Hafif Vinç Sistemlerinde kullanılan özel profillerin ve birlikte kullanılan aksesuarların Türkiye'deki ilk üretimini başlattı.

BM MAKİNA, 2009 yılında, ağırlıklı olarak vinç sektöründeki firmaların ihtiyaç duyduğu Motorlu Kablo toplama Tamburlarını KATO markası altında standart olarak üretmeye başladı.

Bu faaliyetlerine paralel olarak, Türkiye'de hızla gelişen demiryolu taşıma sektörünün ihtiyaç duyduğu bakım atölyesi donanımlarındaki boşluğu değerlendiren BM MAKİNA, 2011 yılında bu kez DEMYKS markası altında Vagon Krikoları imalatına başladı. Başlangıçtaki Mobil Kriko tasarımına daha sonraki yıllarda Yeraltı Kriko Sistemleri, 2 ve 3 eksenli Kaynak Pozisyonerleri, Boji Döner Tablaları, Sabit Vagon Sehpaları ve benzer ürünleri de ekleyerek bu alandaki ürün yelpazesini genişletti ve yurtdışı pazarlara da açıldı.

Artan pazar taleplerini daha iyi karşılamak üzere Gebze Güzeller Organize Sanayi Bölgesindeki 11.000 m² kapalı alana sahip fabrika yatırımını 2011 yılında tamamladı ve bütün birimlerini Gebze'de tek çatı altında topladı.

BM MAKİNA, bugün sayısı 50'yi aşan çalışanından oluşan deneyimli ve dinamik kadrosu ile Gebze fabrikasından Türkiye'nin her yerine ve ayrıca dünyanın birçok ülkesine ürünlerini göndermektedir.

BM MAKİNA, müşterilerinin ihtiyaç ve isteklerine göre farklı kapasite ve özelliklerde tasarlanan, mühendislik ve üretimde uluslararası standartlara uygun, ileri teknolojilere, yüksek güvenlik ve verimliliğe sahip ürünler sunar. Kaliteyi tavizsiz şart olarak benimserken gücünü, en önemli varlığı olan müşterileri ve çalışanlarına olan güveninden alır.



BM MAKİNA Sanayi ve Ticaret A.Ş. was established in 1999 in Istanbul and started its activities in its Perpa Istanbul office as the exclusive representative and distributor for Turkey of energy and data transmission systems manufacturer Vahle - Germany and electric chain hoist manufacturer LIFTKET - Germany.

Having strengthened its position in the market in a short time with its high quality services and products, BM MAKİNA took into consideration the demands of its customers and started local manufacturing activities in 2002 establishing a production facility in DES Industrial Site situated in Dudullu Organized Industrial Zone. In 2003, it started the first production in Turkey of the special profiles and its accessories used in Light Crane Systems under the BKB brand name.

In 2009, BM MAKİNA started to produce Motorized Cable Reels that are mainly needed by companies in the crane sector, under the KATO brand name.

In parallel to these activities, assessing the gaps in the maintenance workshop hardware needed by rapidly evolving rail transport sector in Turkey, BM MAKİNA started manufacturing Wagon Lifting Jacks, this time under the DEMYKS brand in 2011. By adding Underground Jack Systems, 2 and - 3 axis Welding Positioners, Bogie Turntables, Fixed Wagon Stands and similar products to the initial Mobile Jack design, it expanded its product range in this field and opened door to foreign markets.

In order to better meet the increasing market demands, it completed its factory investment having a closed area of 11.000m² in Gebze Güzeller Organized Industrial Zone in 2011 and gathered all its units under one roof in Gebze.

BM MAKİNA, with an experienced and dynamic team of more than 50 employees, dispatches their products direct from its factory in Gebze to everywhere in Turkey and also to many countries all over the World.

BM MAKİNA offers products designed in different capacities and features according to the needs and requests of its customers, in accordance with international standards in engineering and production, with advanced technologies, high safety and efficiency. While adopting quality as an uncompromising condition, it draws its strength from its most important assets, its customers and confidence in its employees.



Alüminyum BKB Vinç Sistemleri, 1000 kg yük kapasitesine kadar olan uygulamalar için BM Makina A.Ş. tarafından tasarlanıp tamamen Türkiye'de üretilmektedir. Sistem genel olarak yükleri elle taşımak için kullanılmakta olup en az sürtünmeyle sessiz ve darbesiz çalışmaya imkan verir. Talep edildiğinde ALU 1000 boy profile sahip sisteme Elektrikli Çekici Araba eklenerek elektrik tahrikli yük taşıma seçeneği de sunulmaktadır.

Düşük yanaşma mesafelerine sahip olması nedeniyle Alüminyum BKB Vinç Sistemleri fabrika ve atölye içi dar alanlarda kullanılmaya çok uygundur.

Genel Uygulama Alanları;

- Sürekli montaj hatları
- Tekli montaj alanları
- Tezgah üzeri vinçler
- Hammadde besleme vinçleri
- Genel amaçlı fabrika ve atölye içi monoray, gezer köprülü, portal ve pergel vinçler

Aluminium BKB crane systems are designed and completely manufactured in Turkey by BM Makina A.Ş. for applications up to 1000 kg capacity. The system is generally used for manual load transport and allows quite and smooth operation with minimum friction. If requested, electrically driven load transfer alternative can also be offered by adding Electrical Traction Drive to the system with ALU 1000 size profile.

Hope to their small approach distances, Aluminium BKB crane systems are ideal for use inside factories' and workshops' narrow areas.

General Application Fields

- Continuous assembly lines
- Individual assembly areas
- Cranes over machine tools
- Raw material feeding cranes
- General purpose monorail, overhead travelling, gantry and jib types light cranes in factories and workshops

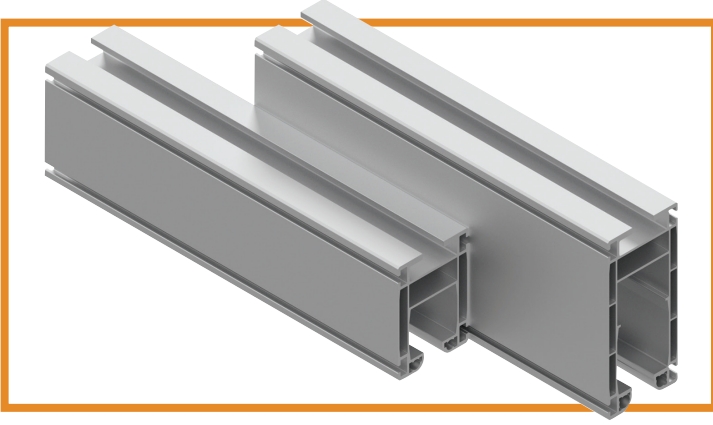

HAFİF YÜK UYGULAMALARI İÇİN ERGONOMİK VE İDEAL ÇÖZÜM

- Yük iletiminde yüksek hız ve zaman tasarrufu
- Diğer iletim sistemlerine göre kullanımda %50 daha az güç gereksinimi



KOLAY YAPILANDIRILABİLİR SİSTEM

- Zengin aksesuar ve parça seçeneği sayesinde müşteri talebine özel esnek ve modüler sistem
- Optimum verimlilik

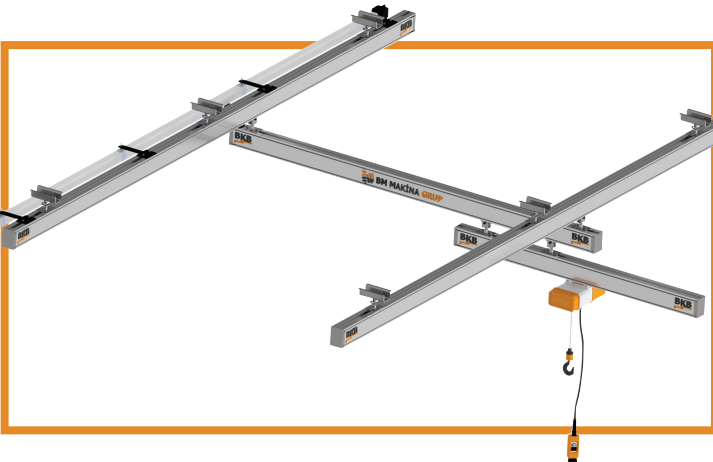

HIZLI TESLİMAT VE KURULUM

- Kolay ve hızlı kurulum
- İmalatın tamamen fabrikamızda yapılması sayesinde kısa sürede teslimat

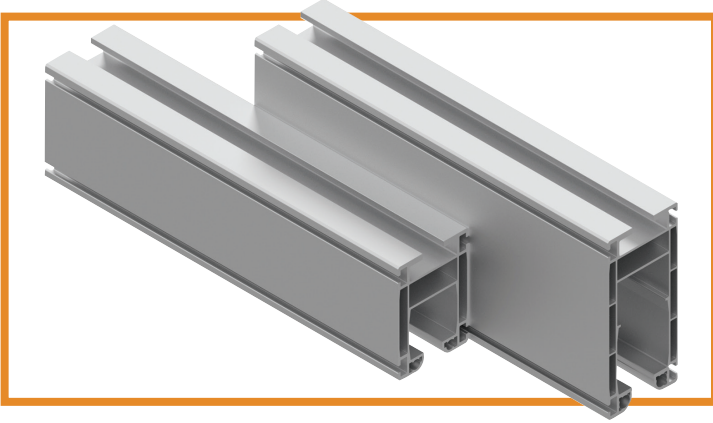

ERGONOMIC AND IDEAL SOLUTION FOR LIGHTWEIGHT APPLICATIONS

- High speed and time saving in load transmission
- 50% less power need comparing with other alternative transfer systems

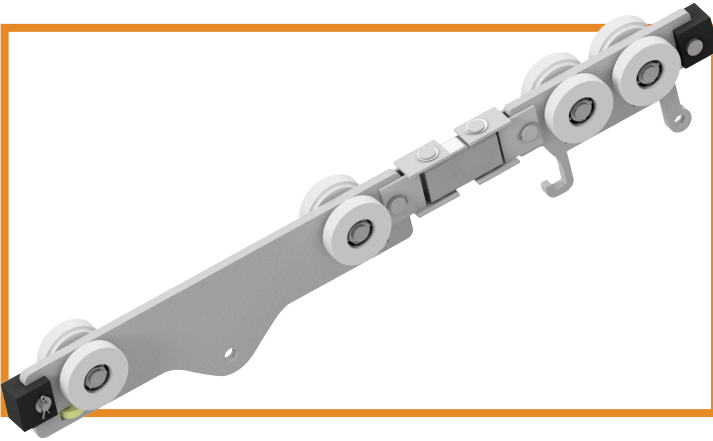

EASILY CONFIGURABLE SYSTEM

- Fully customized, flexible and modular system hope to wide range of accessories and components
- Optimum productivity



QUICK DELIVERY AND INSTALLATION

- Easy and quick installation
- Fast delivery hope to complete manufacturing in our factory

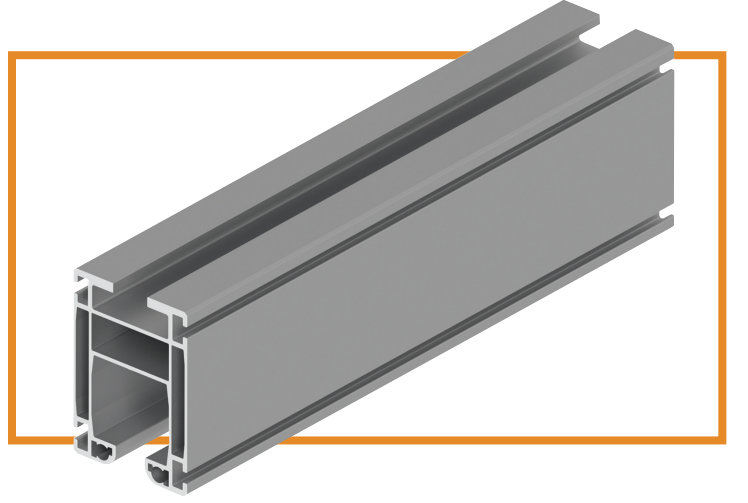
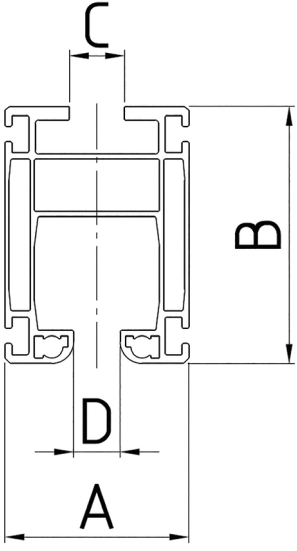

Katalog Numarası/Catalogue Number	Max. Yükleme/Max. Load	A	B	C	D
17017.00.001.-.-	500 Kg	100	140	30	25,2

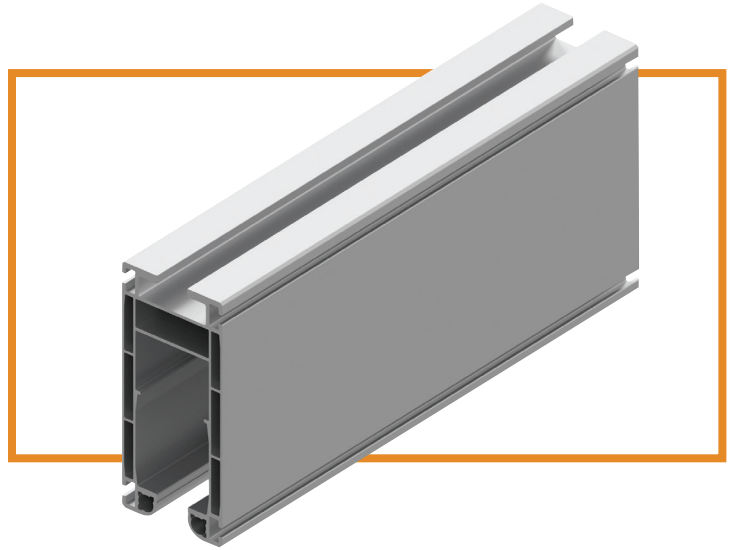
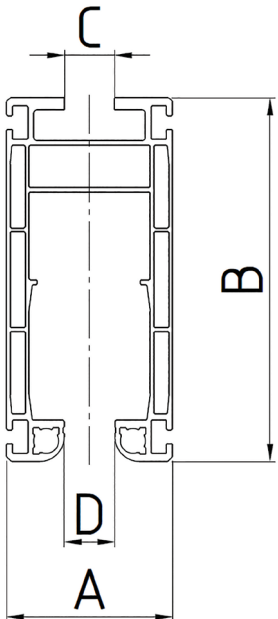

Katalog Numarası/Catalogue Number	Max. Yükleme/Max. Load	A	B	C	D
17018.00.001.-.-	1000 Kg	100	220	30	30,5

BAŞLIK ARABASI #1 / END CARRIAGE #1

ALU BKB

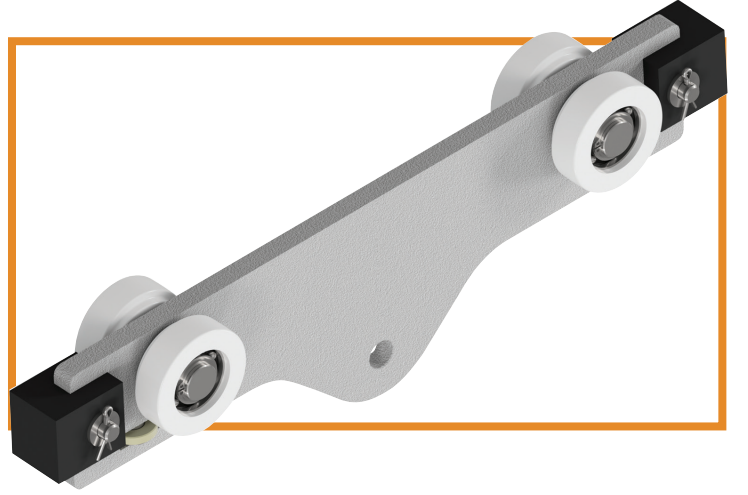
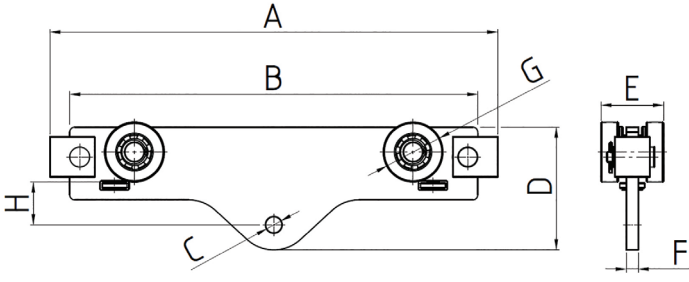

Katalog Numarası/Catalogue Number	Profil Tipi/Profile Type	A	B	C	D	E	F	G	H
17017.09.000.-.-	ALU 500	450	410	Ø16	123	63	12	Ø60	43
17018.05.000.-.A	ALU 1000	540	500	Ø16	145	68	12	Ø80	50

BAŞLIK ARABASI #2 / END CARRIAGE #2

ALU BKB

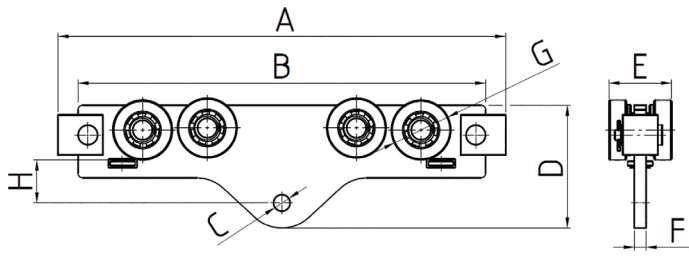

Katalog Numarası/Catalogue Number	Profil Tipi/Profile Type	A	B	C	D	E	F	G	H
17017.11.000.-.-	ALU 500	450	410	Ø16	123	63	12	Ø60	43
17018.07.000.-.A	ALU 1000	540	500	Ø16	145	68	12	Ø80	50

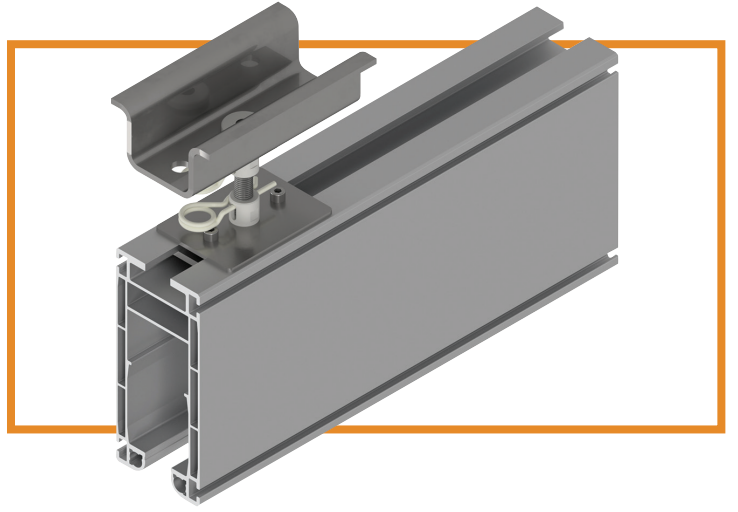
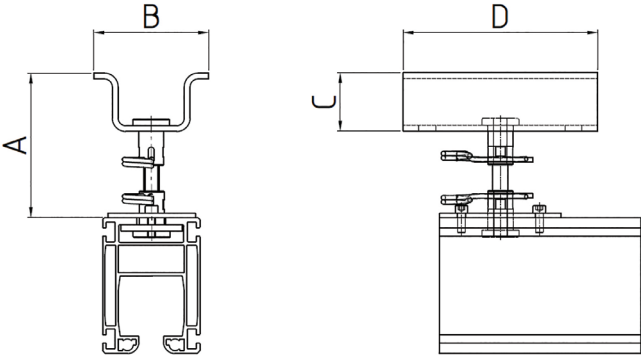

Katalog Numarası/Catalogue Number	Profil Tipi/Profile Type	A	B	C	D
17017.07.000.-.-	ALU 500 & ALU 1000	149	118	60	200

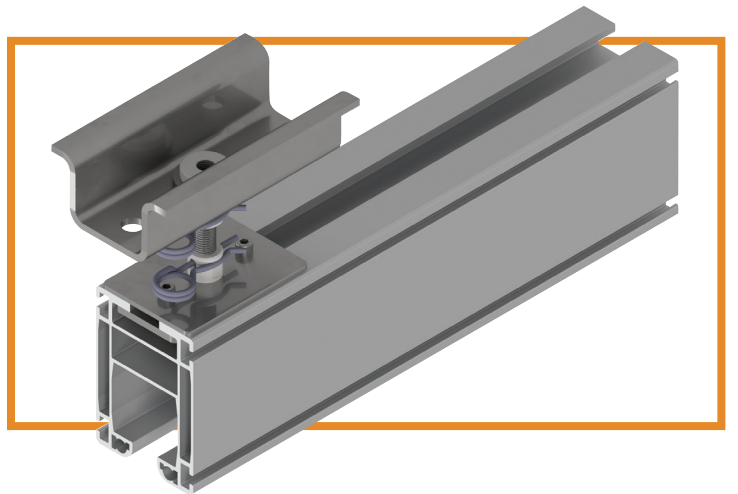
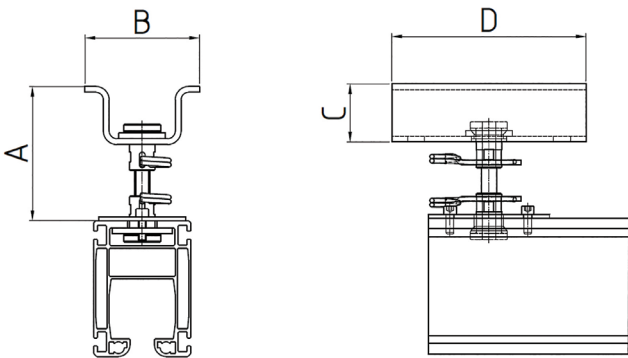

Katalog Numarası/Catalogue Number	Profil Tipi/Profile Type	A	B	C	D
17017.06.000.-.-	ALU 500 & ALU 1000	139	118	60	200

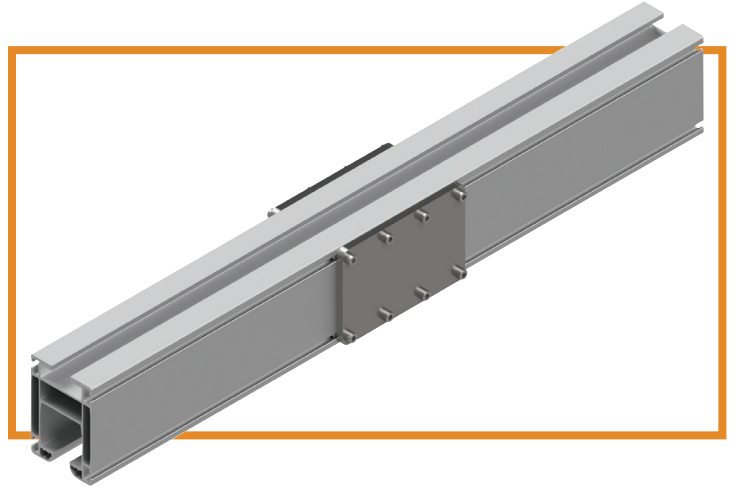
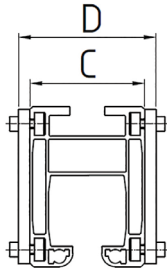
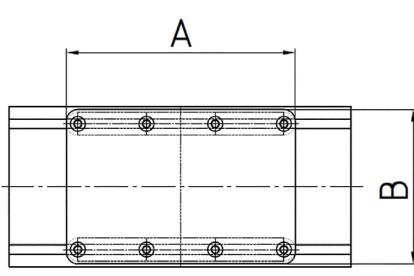

Katalog Numarası/Catalogue Number	Profil Tipi/Profile Type	A	B	C	D
17017.01.000.-.-	ALU 500	200	135	120	100
17018.01.000.-.-	ALU 1000	200	215	120	100

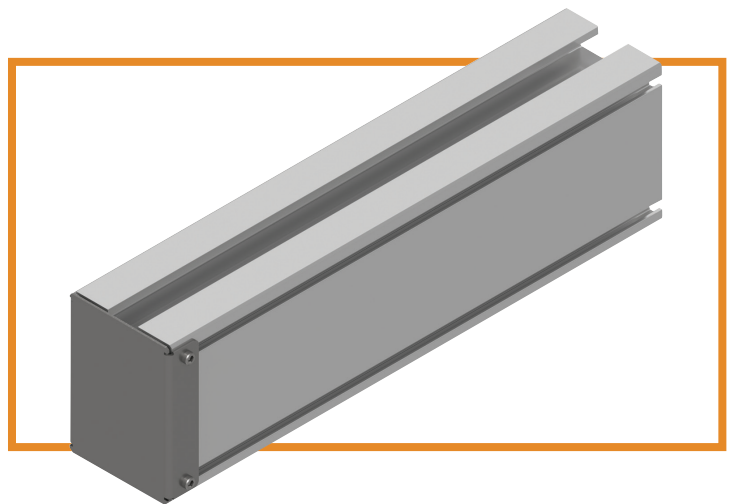
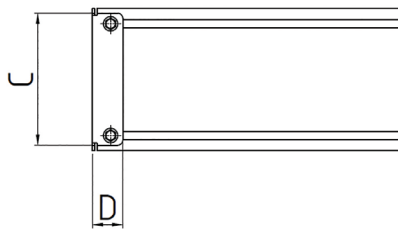
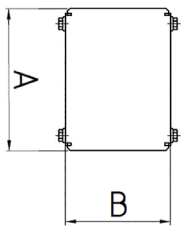

Katalog Numarası/Catalogue Number	Profil Tipi/Profile Type	A	B	C	D
17017.03.003.-.-	ALU 500	140	104	130	30
17018.03.001.-.-	ALU 1000	220	104	210	40

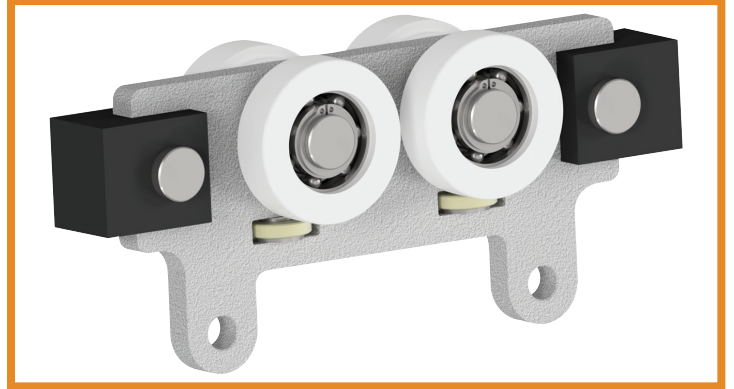
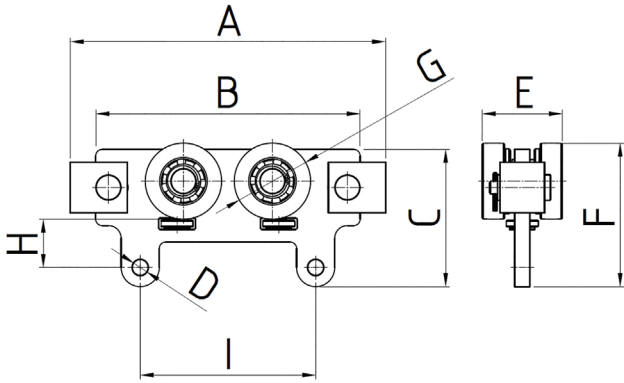

Star Liftket									
Model	020/50	020/52	021/57	021/53	020/54	021/51	030/50	030/52	

Katalog Numarası/Catalogue Number	Profil Tipi/Profile Type	A	B	C	D	E	F	G	H	I
17017.13.01.000.-.-	ALU 500	248	208	108	Ø12.2	63	113	Ø60	38	138
17018.11.01.000.-.-	ALU 1000	280	240	136	Ø12.2	68	140	Ø80	45	138

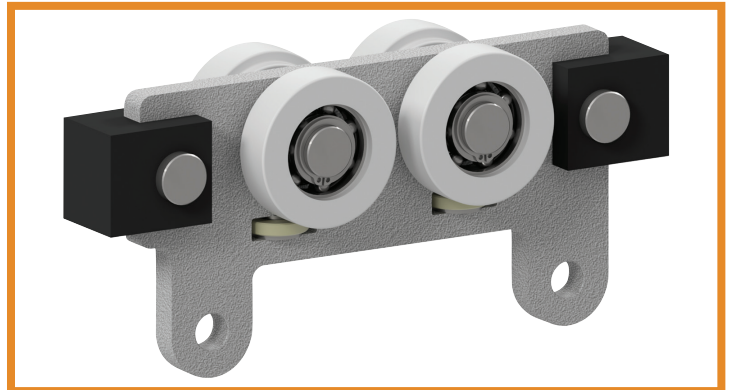
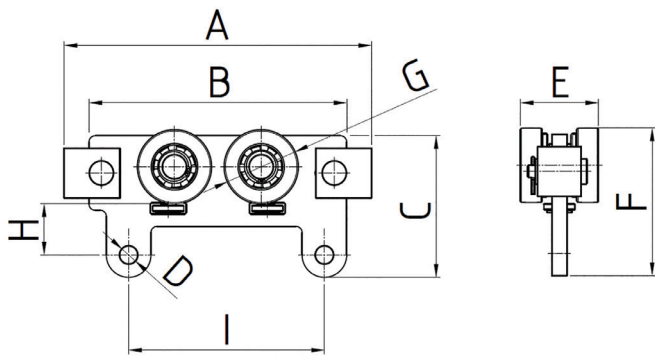

Star Liftket													
Model	051/50	050/52	051/52	051/55	070/51	071/54	071/53	070/54	070/55	070/53	071/55	070/56	071/56

Katalog Numarası/Catalogue Number	Profil Tipi/Profile Type	A	B	C	D	E	F	G	H	I
17017.13.02.000.-.-	ALU 500	248	208	114	Ø14.2	63	119	Ø60	41	158
17018.11.02.000.-.-	ALU 1000	280	240	136	Ø14.2	68	146	Ø80	48	158

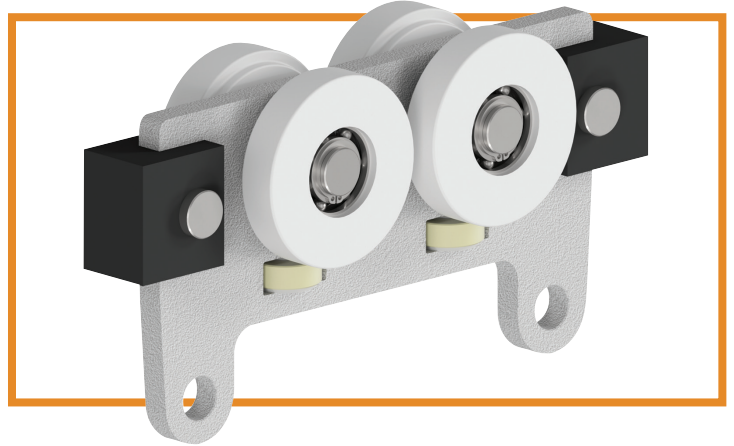
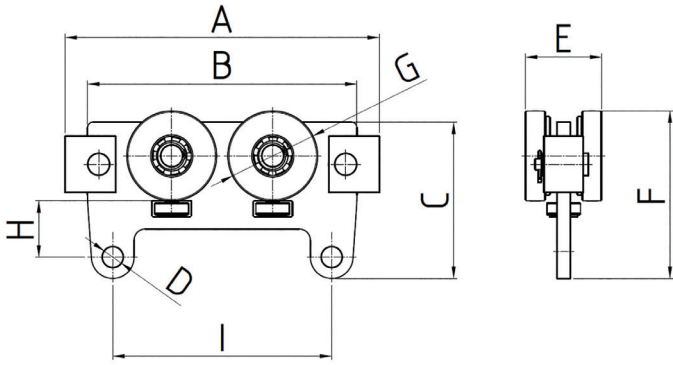

Star Liftket										
Model	090/54	090/52	091/51	091/52	090/55	091/55	091/56	091/58	091/57	

Katalog Numarası/Catalogue Number	Profil Tipi/Profile Type	A	B	C	D	E	F	G	H	I
17018.11.03.000.-.-	ALU 1000	280	240	139	Ø18.2	68	149	Ø80	50	195

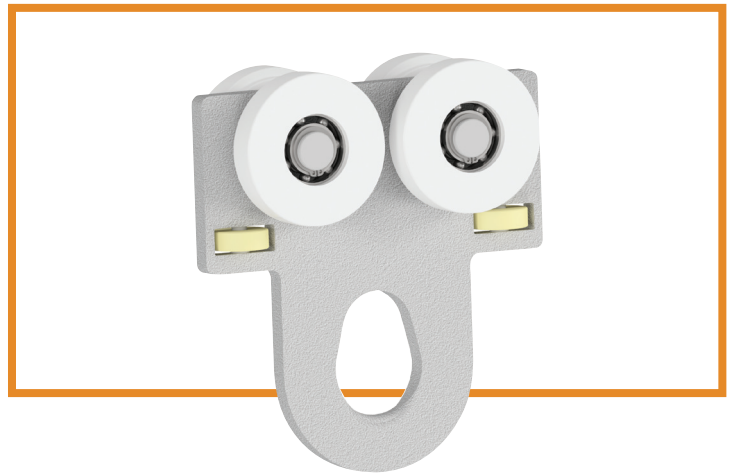
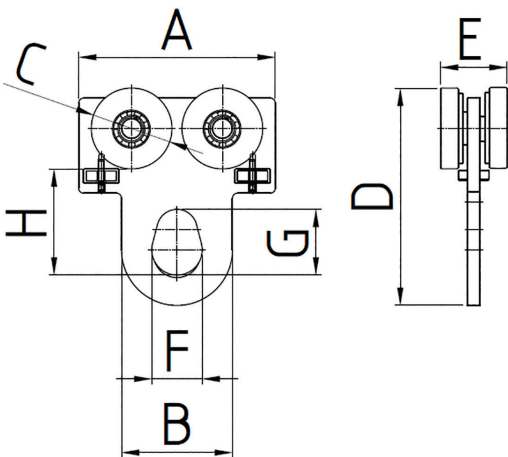

Katalog Numarası /Catalogue Number	Profil Tipi/Profile Type	A	B	C	D	E	F	G	H
17017.08.000.-.-	ALU 500	170	110	Ø60	188	63	50	65	98
17018.04.000.-.-	ALU 1000	195	110	Ø80	215	68	50	65	105

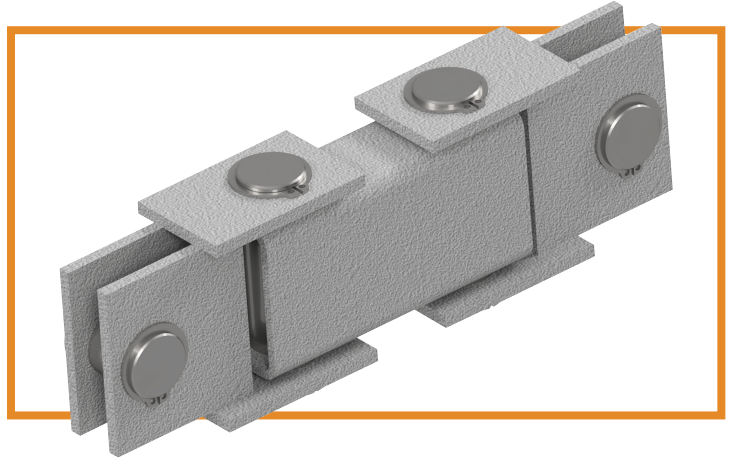
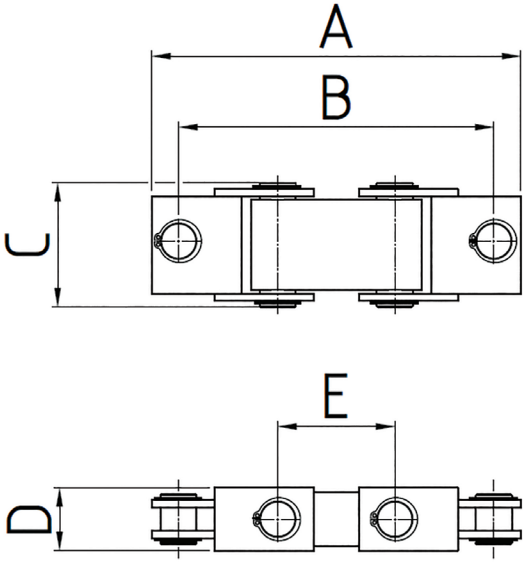

Katalog Numarası/Catalogue Number	Profil Tipi/Profile Type	A	B	C	D	E
17018.10.000.-A	ALU 1000	205	175	69	35	65

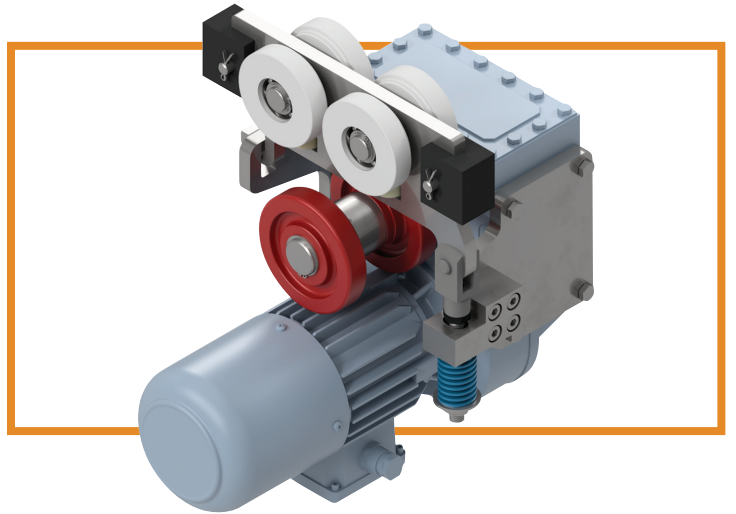
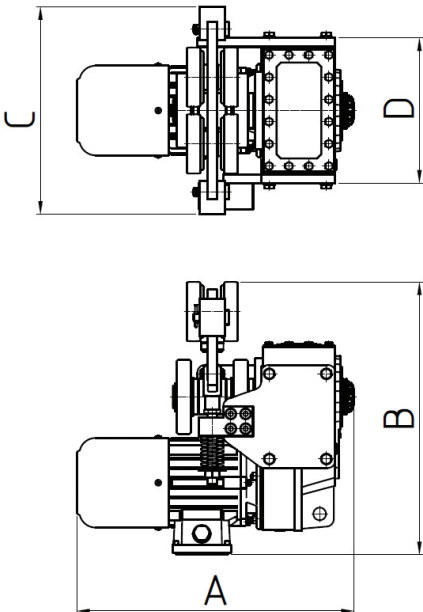

Katalog Numarası/Catalogue Number	Profil Tipi/Profile Type	A	B	C	D
17018.12.000.-.-	ALU 1000	374,5	368	280	196

NOTLAR

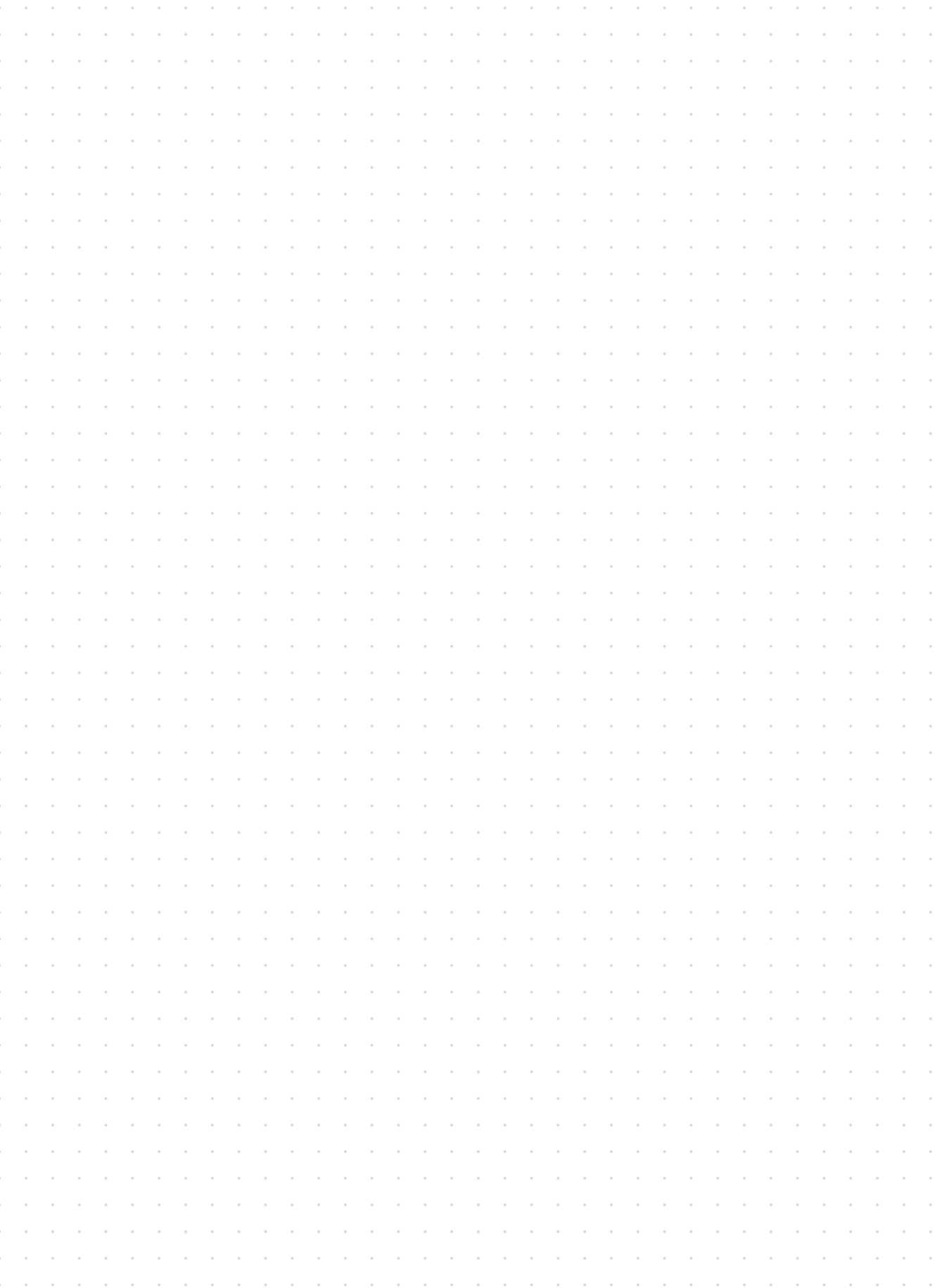

NOTLAR

A large grid of small dots for taking notes, consisting of 20 columns and 30 rows of dots.



BM MAKİNA GRUP

Bm Makina Sanayi ve Ticaret Anonim Şirketi
İnönü Mahallesi Gebze Güzeller Organize Sanayi Bölgesi
Ebulfez Elçibey Sokak No:20-2 Gebze / Kocaeli / TÜRKİYE
Tel: + 90 262 751 02 08 pbx - Fax: + 90 262 751 08 22
e-mail: info@bmmakina.com.tr
www.bmmakina.com.tr