



MOTOR POWERED CABLE REELS

VAHLE 
ELECTRIFICATION SYSTEMS



VAHLE MOTOR POWERED CABLE REELS

INDEX		Page	
Introduction		2, 3	
Cable selection		4	
Typical applications		5	
Questionnaire		6, 7	
		Torque Motor Series	Magnet Coupling Series
Model explanation		8	36
Reel selection charts	monospiral wrap, horizontal payout	9-13, 16	37-40
	random wrap, horizontal payout	19-21, 23-25	45-47
	random wrap, vertical lift	26 27	48, 49
Dimensions	14, 15, 17, 28, 29	41, 42 / 50, 51	
Resistors	30, 31		
Wiring diagrams	32, 33		52
Features			35
Accessories	cable guides	53	
	double sheave guides	54	
	feed point funnels, terminal box	55	
	cable grips, turnover anchor clamps, cable support rollers	56	
Further Models	for special heavy duty & high speed applications	57-59	
VAHLE Reels Fotos			18, 22, 34, 43, 44
All VAHLE Electrification Systems			Back Cover

Introduction

Foreword

Our motor driven cable reels serve the industry for reliable electrification of equipment in motion; for automatic winding of flexible power- and control-cables. They fully meet international safety requirements.

Applications

include Portal-, Gantry- and Container-Cranes, Dockside-, Ship- and Construction-Cranes, Grabs and Magnets, Electric Hoists and other material-handling, -lifting, -stacking and -storing equipment.

This comprehensive line of precision designed and quality-built reels is also a proven automatic 'cable and hose care taker' in the following instances:

- VAHLE Reels on board ships or in the tropics.
- VAHLE Reels in aggressive environments (galvanizing plants, pickling lines, sewage treatment systems).
- VAHLE Reels in explosionsproof versions (slipringless).
- VAhle Reels for Control-, Signal- and Highfrequency-Transmission.
- VAHLE Reels for Air, Liquids and Gases (Hose Reels).
- VAHLE Reels for handling steel ropes in travel distance tracking systems and for grab stability on heavy cranes (Tag Line Reels).
- VAHLE Reels for Curves and for Endless Monorails with special swivel base.
- VAHLE Reels of the lift & lower type for multi level machine tools and for push-botton pendants.

Vahle welcomes your inquiry on your particular application.



Electrical Properties of Sliprings

Standard sliprings are rated for 690 Volt AC and 900 Volt DC; Control Rings in block system for 500 Volts.

Indicated collector ring ampere capacities are for 60 % nominal rating.

200 Amp and 400 Amp collector ring sizes are used for 6/10 kV high voltage applications. Reels beyond these capacities are available upon request.

Protection Code

Slipring enclosures are designed to IP 54; protected against harmful dust deposits and splash water proof per DIN 40050. Higher grade protection available upon request.

A thermostatically controlled heater is installed on high voltage reels (and can be supplied on standard reels) to prevent condensation moisture.

Drive System

The following drive systems are employed:

- Torque motor, squirrel cage type
- Torque motor, slipring type with std. or step resistor
- AC motor with magnet coupling

Further models from our wide range of heavy duty and high speed reels include:

- Torque motor, slipring type with electronic control
- Hydraulic drive with constant torque
- Hydraulic drive with variable torque for constant cable tension

Cable Payout

is normally following the technical information and drawings of this catalog.

Other requirements can be fulfilled; e. g. opposite hand rotation.

Limit Switch Assemblies

for switching off travel and hoist motors with one or two safety windings on the reel are optional.

In conjunction with torque control systems we do supply cam-type limit switches.

Accident Prevention

All moveable parts of the drive system, e. g. chaindrive are covered in accordance with the accident prevention code.

Therefore, the cable reels can be installed in work areas as well as traffic areas. Additional protective devices, such as a cover for the revolving reel body itself, are to be furnished and fitted at site.

Corrosion Protection

The random wrap reel series is galvanized. All other reels come with one primer coat and one finishing paint of epoxy-resin RAL 2002 orange-red varnish; Motor and Gearings in RAL 5009 azure-blue.

Reel Selection

Choosing the proper cable reel from the VAHLE Reel Selection Charts has been made as easy as possible.

All you have to know is:

- ▶ Cable data
 - Wire size and number of conductors
 - Diameter
 - Weight
 - Min. bending radius
- ▶ Active cable length
- ▶ Max. operating speed of your equipment

The capacities of the cable reels in this catalog are based on cables listed in the Reel Selection Charts allowing one safety winding for standard voltage or two safety windings for high voltage applications; considering an ambient temperature of -10°C up to $+40^{\circ}\text{C}$ and an acceleration factor of $0,2\text{ m/sec}^2$.

For other conditions, consult factory and use our questionnaire pages 6 & 7.

Cable Length

Reels are designed to handle a certain type and length of cable in a specific manner. Never use reels for more cable than outlined in the selection charts.

The total cable length required results from maximum payout length (active cable) plus reel installation height plus one or two safety windings plus hook-up length for connections.

Installation Information

Installation instructions and operation manuals for commissioning advice and assistance are attached to each reel shipment and found in the slipring housing.



CABLE SELECTION

**Table 1: Continuous ampacity of cables type NSH . . . and NTS . . . for stretched, open air laying.
Max. permissible operation temperature of the conductor 90° C.**

Wire size [mm ²]	Continuous ampacity [A] at 30 ° C	f_{ED}	Multiplier for intermittent service				Z [Ω / km]
			60%	40%	25%	15%	
1,5	23		1,00	1,00	1,00	1,00	8,770
2,5	30		1,00	1,00	1,04	1,07	5,310
4	41		1,00	1,03	1,05	1,19	3,360
6	53		1,00	1,04	1,13	1,27	2,250
10	74		1,03	1,09	1,21	1,44	1,370
16	99		1,07	1,16	1,34	1,62	0,888
25	131		1,10	1,23	1,46	1,79	0,587
35	162		1,13	1,28	1,53	1,90	0,443
50	202		1,16	1,34	1,62	2,03	0,344
70	250		1,18	1,38	1,69	2,13	0,258
95	301		1,20	1,42	1,74	2,21	0,205
120	352		1,21	1,44	1,78	2,26	0,174
150	404		1,22	1,46	1,81	2,30	0,154
185	461		1,23	1,48	1,82	2,32	0,136
240	540		1,23	1,49	1,85	2,36	0,119

Table 2: Multiplier for ambient temperature

Ambient temperature [°C]	25	30	35	40	45	50	55	60	65
Correction factor f_T	1,05	1,00	0,95	0,89	0,84	0,77	0,71	0,63	0,55

Table 3: Multiplier for multi-layer service

Number of full layers on reel	1*	2	3	5
Correction factor f_l	0,80	0,61	0,49	0,38

Table 4: Multiplier for multi-conductor service, up to 10 mm² wire size

Number of conductors in service	5	7	10	14	19	24	40	61
Correction factor f_2	0,75	0,65	0,55	0,50	0,45	0,40	0,35	0,30

* also for spiral winding.

Table 5: Minimum bending radii, apply to cables listed in this catalog. Observe supplier's recommendations for other cables.

Type of cable	Nominal voltage up to 0,6 / 1 kV			Nominal voltage above 0,6 / 1 kV	Remarks
Flexible cables	Overall diameter of cable in mm			6 x d	Consult the factory in critical cases.
	above 8 - 12	above 12 - 20	above 20		
fixed installation	3 x d	4 x d	4 x d		
fully flexible installation	4 x d	5 x d	5 x d		
for entry	4 x d	5 x d	5 x d		
for forced guidance with reeling operation	5 x d	5 x d	6 x d		
for forced guidance with rollers/sheaves	7,5 x d	7,5 x d	7,5 x d	15 x d	

The minimum distance
with double or S-type directional changer is
20 x overall cable diameter.

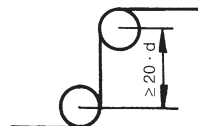

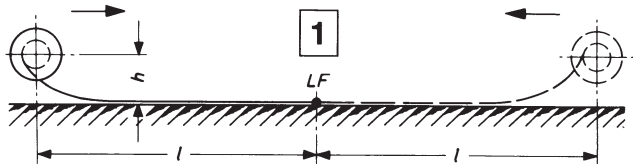

retrieve

Reel is mounted on the moving equipment, picks up cable from the floor or other surface. One- or two-way horizontal payout. The application becomes a modified retrieve lift when reel mounts too high for cable drag without guide.

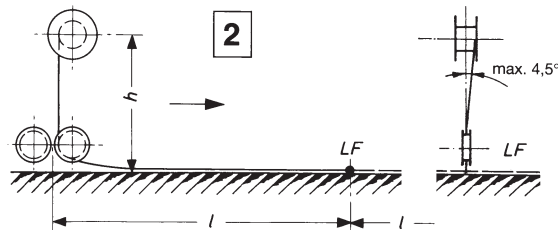

retrieve lift

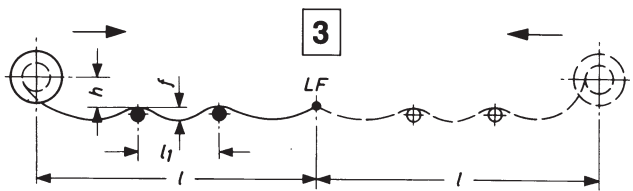

retrieve

Much the same as above, however cable recovery from round support brackets or rollers at regular intervals; l_1 for brackets max. 1 m, for rollers 1 up to 3 m.

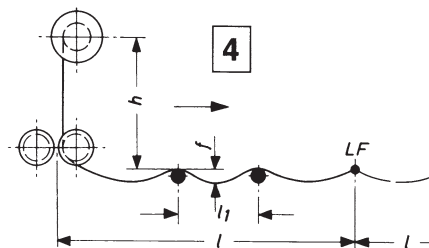

retrieve lift

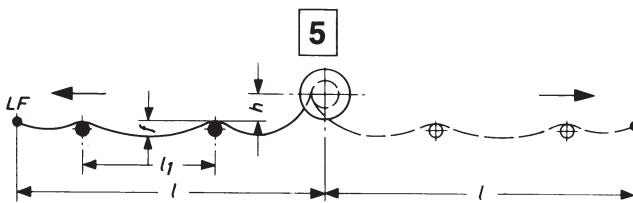

drag

In this case the reel is stationary. Cable is dragged over round supports or rollers to and from the reel, in one or two directions ($l_1 \leq 3$ m).

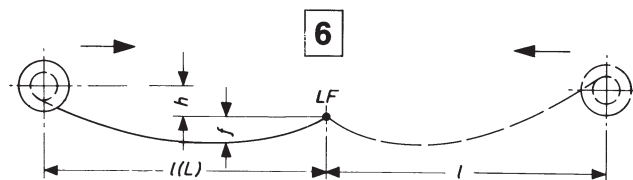

horizontal stretch with reel on moving equipment

Cable is suspended horizontally, supported only at both ends, allowing a sag (f) in relation to l or L whatever is longer.

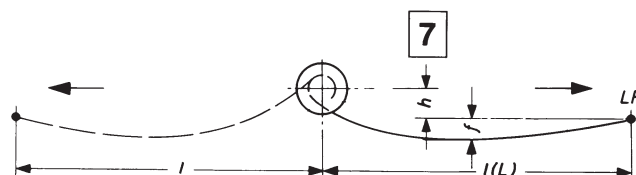

horizontal stretch with stationary reel

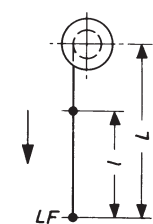

vertical lift

Reel is mounted overhead. Cable pays out and is retracted vertically. Total cable weight plus any extra load (pushbutton station, etc.) must be considered. The latter does not apply to case 9 where the reel is located below rather than above.

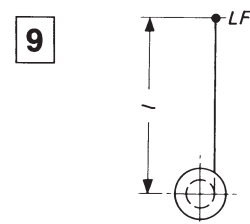

vertical retrieve

Legend to Drawings:

- l = operational (active) length of cable
- l_1 = support intervals
- L = max. length between reel and end of cable
- LF = feed point or connection to moving member
- h = height of reel above recovery surface
- f = cable sag

For applications 3 thru 7 and 9 and reels beyond the listed capacities, please contact your local VAHLE representative or the factory.

Use the reel data form on pages 6 & 7 of this catalog.

Having all the facts will ensure determining of the best reel for your specific requirement.



QUESTIONNAIRE

1. For what type of moving equipment is the reel? _____
(Dimensional drawings of equipment and application are extremely valuable)

1.1 Installation site indoor outdoor

1.2 Temperature conditions - ____°C + ____°C

1.3 Duty factor (time on) of full operating load _____ % DF

1.4 Environmental conditions _____

2. Type of application (see page 5) case

2.1 Spool type random wrap monospiral wrap

3. Mounting height from center of spool to cable pickup surface _____ m

4. Working travel of equipment in motion _____ m

5. Cable Payout one-way two-way

6. Operational length of active cable $l =$ _____ m
(Midway fee-point cuts the length of cable needed in half)

6.1 For vertical lift (see page 5, case 8) $l =$ _____ m, $L =$ _____ m

6.2 Operated from a remote point to raise and lower cable at a controlled speed? yes , no

6.2.1 Loads in addition to cable weight (pendant controls or power receptacles) _____ kg or _____ lbs

7. Chosen Cable (Number of copper conductors x wire size) _____ x _____ mm² or _____ # AWG

7.1 Weight of cable _____ kg/m or _____ lbs/ft.

7.2 Diameter of cable _____ mm or _____ in.

8. Full operating load or maximum horsepower of equipment _____ kW or _____ HP

8.1 Nom. amperage (nominal current - I_N) _____ A

8.1.1. Start. amperage (starting current - I_A) _____ A

8.2 Voltage rating / frequency _____ V _____ Hz

9. What percentage of the total installed ampacity will work simultaneously? _____ %

10. Number of phase collector rings required? _____ pcs.
(Our cable reel slipring assemblies always include one non-insulated ground)

11. How many movements of the equipment per hour? _____ times

12. Operating hours per day _____ hours

13. Speed of travel or lift _____ m/min.

14. Acceleration zero to full speed _____ sec.

15. Acceleration rate _____ m/sec².

16. Details for reel drive motor

16.1 Voltage / frequency _____ V _____ Hz

16.2 Duty cycle _____ % DF

17. Limit switch for travel or lift required? yes no

Remarks: _____



To our nearest local VAHLE-agency:

Customer: _____

Address: _____

Attention of: _____

Date: _____

Motor data	Crane 1			Crane 2			Crane 3		
	Power kW/HP	Current Amps	Duty factor %	Power kW/HP	Current Amps	Duty factor %	Power kW/HP	Current Amps	Duty factor %
Hoist motor									
Auxiliary hoist									
Travel motor - main-trolley									
Travel motor - aux.-trolley									
Main travel									
Slewing									
Luffing									

Mark with* any motor that may be in simultaneous operation.

Additional Comments: _____



LT MODEL EXPLANATION

Reel Type Definition

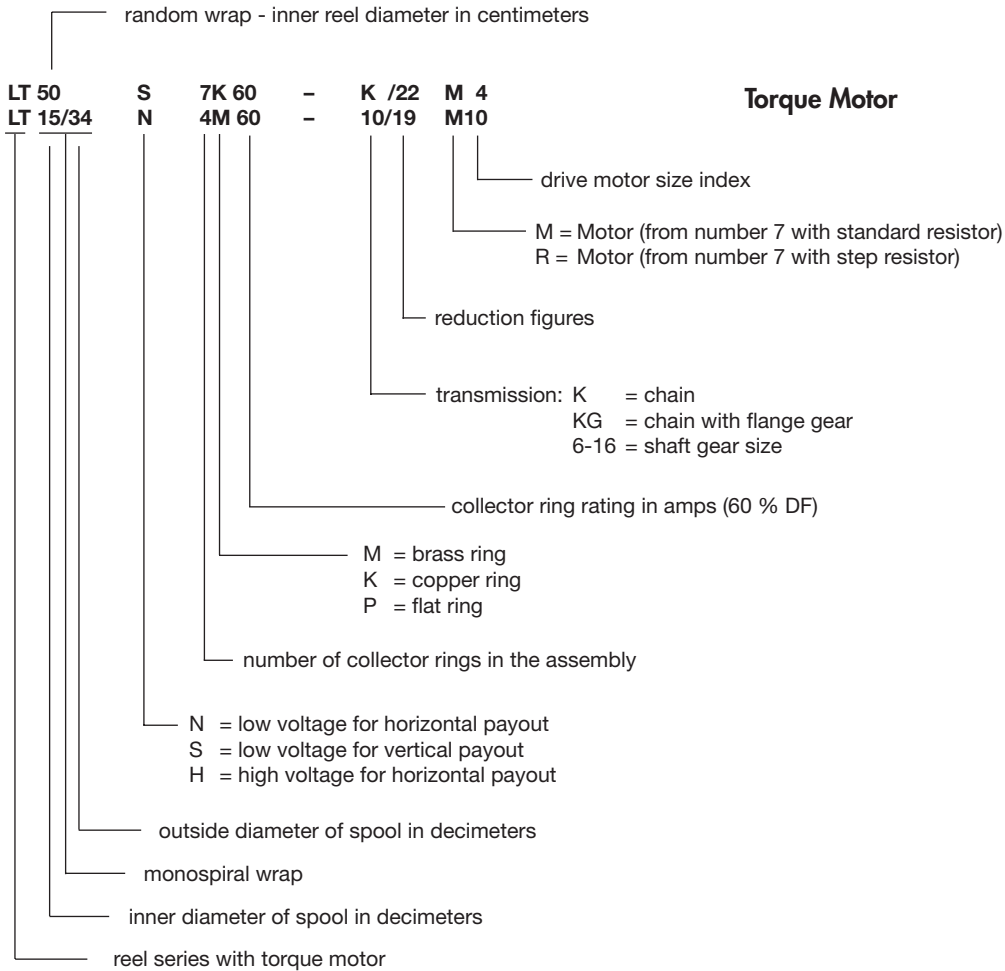

Frequency converter-drive (FU)

**All models
are less cable**

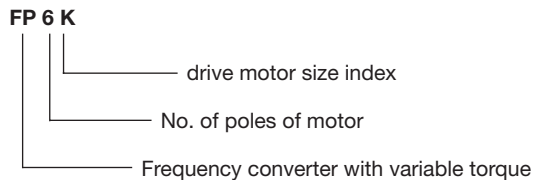
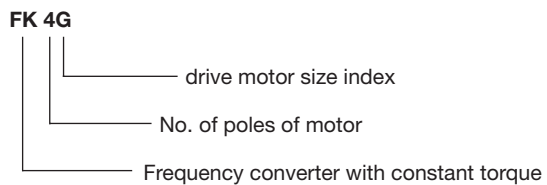

Reel Selection - Example

Job function requiring a reel for:

Active cable length	: 30 m
No. of conductors x wire size	: 4x6 mm ²
Cable diameter	: 21 mm
Cable weight	: 0.6 kg/m
Operating speed	: 20 m/min
Application	: case 1
Spool type	: monospiral

The selection per chart on page 9:

Type : **LT 6/12 N 4M60 - 6/25 M3**
Cat.-No. : **0920002**

REEL SELECTION CHART

Monospiral wrap, shaft gear, horizontal payout

Applications

1 2



Cable NSHTÖU-J 4 x 6 mm ²		Ø 21 mm				Weight: 0,6 kg/m	
active length [m]	Reel Type	12 m/min.	20 m/min.	30 m/min.	40 m/min.	60 m/min.	80 m/min.
30	LT 6/12 N 4 M 60-	6/36 M2 0920001	6/25 M3 0920002	6/17 M4 0920003	8/13 M5 0920004	-	-
57	LT 6/15 N 4 M 60-	6/36 M3 0920005	6/22 M4 0920006	6/17 M5 0920007	8/12 M6 0920008	-	-
79	LT 8/18 N 4 M 60-	6/60 M2 0920009	6/29 M4 0920011	6/22 M5 0920012	8/16 M6 0920013	-	-
126	LT 8/21 N 4 M 60-	6/51 M3 0920014	6/32 M4 0920015	6/25 M5 0920016	8/19 M6 0920017	6/15 M9 0927001	6/29 FK 4D 0927002
Cable NSHTÖU-J 4 x 10 mm ²		Ø 25,5 mm				Weight: 0,95 kg/m	
25	LT 6/12 N 4 M 60-	6/45 M2 0920018	6/20 M4 0920019	6/17 M5 0920021	6/15 M8 0920022	-	-
48	LT 6/15 N 4 M 60-	6/45 M3 0920023	6/25 M4 0920024	6/17 M8 0920025	6/17 M8 0920026	-	-
68	LT 8/18 N 4 M 60-	6/51 M3 0920028	6/32 M4 0920029	6/22 M8 0920031	6/22 M8 0920032	-	-
104	LT 8/21 N 4 M 60-	6/60 M3 0920035	6/32 M 5 0920036	6/25 M8 0920037	6/17 M9 0920038	8/13 M10 0927003	6/36 FK 4D 0927004
133	LT 12/25 N 4 M 60-	8/76 M3 0920042	8/50 M4 0920043	8/32 M8 0920044	8/32 M8 0920045	-	-
Cable NSHTÖU-J 4 x 16 mm ²		Ø 30 mm				Weight: 1,4 kg/m	
19	LT 6/12 N 4 M150-	6/36 M3 0920048	6/22 M4 0920049	6/22 M7 0920051	6/15 M8 0920052	-	-
38	LT 6/15 N 4 M150-	6/45 M3 0920054	6/25 M5 0920055	6/20 M8 0920056	6/15 M9 0920057	8/12 M10 0927005	6/25 FK 4D 0927006
56	LT 8/18 N 4 M150-	6/60 M3 0920059	6/29 M5 0920061	6/25 M8 0920062	6/17 M9 0920063	8/13 M10 0927007	6/36 FK 4D 0927008
85	LT 8/21 N 4 M150-	6/51 M4 0920066	6/45 M7 0920067	6/32 M8 0920068	6/20 M9 0920069	8/16 M10 0927009	6/29 FK 4E 0927010
109	LT 12/25 N 4 M150-	8/57 M4 0920073	8/50 M5 0920074	8/41 M8 0920075	8/25 M9 0920076	8/19 M10 0927011	8/50 FK 4D 0927012
153	LT 15/30 N 4 M150-	8/76 M4 0920079	8/67 M5 0920081	8/50 M8 0920082	8/32 M9 0920083	8/25 M10 0927013	8/67 FK 4D 0927014
Cable NSHTÖU-J 4 x 25 mm ²		Ø 35 mm				Weight: 1,9 kg/m	
16	LT 6/12 N 4 M150-	6/45 M3 0920086	6/29 M4 0920087	6/17 M8 0920088	6/17 M8 0920089	6/12 M9 0927015	6/25 FK 4D 0927016
32	LT 6/15 N 4 M150-	6/36 M4 0920092	6/29 M5 0920093	6/22 M8 0920094	6/15 M9 0920095	8/12 M10 0927017	6/32 FK 4D 0927018
48	LT 8/18 N 4 M150-	6/45 M4 0920097	6/36 M5 0920098	6/29 M8 0920099	6/20 M9 0920101	8/16 M10 0927019	6/45 FK 4D 0927020
72	LT 8/21 N 4 M150-	6/60 M4 0920104	67/36 M8 0920105	6/25 M9 0920106	8/16 M10 0920107	6/51 FK 4D 0927021	6/36 FK 4E 0927022
92	LT 12/25 N 4 M150-	8/67 M4 0920111	8/67 M7 0920112	8/28 M9 0920113	8/28 M9 0920114	8/22 M10 0927023	8/50 FK 4E 0927024
133	LT 15/30 N 4 M150-	8/96 M4 0920117	8/85 M7 0920118	8/41 M9 0920119	8/41 M9 0920121	8/85 FK 4D 0927025	8/57 FK 4E 0927026

Drive system - Torque motor

Drive system - Torque motor with frequency converter



REEL SELECTION CHART

Monospiral wrap, shaft gear, horizontal payout

Applications

1 2

Cable NSHTÖU-J 4 x 25 mm ²		Ø 35 mm				Weight: 1,9 kg/m	
active length [m]	Reel Type	12 m/min.	20 m/min.	30 m/min.	40 m/min.	60 m/min.	80 m/min.
150	LT 12/30 N 4 M150-	8/76 M5 0920124	8/67 M8 0920125	8/41 M9 0920126	8/28 M10 0920127	8/85 FK 4D 0927027	8/41 FK 6E 0927028
182	LT 15/34 N 4 M150-	10/94 M5 0920131	10/84 M8 0920132	10/54 M9 0920133	10/38 M10 0920134	10/84 FK 4E 0927029	10/54 FK 4F 0927030
Cable NSHTÖU-J 4 x 35 mm ²		Ø 39,5 mm				Weight: 2,6 kg/m	
13	LT 6/12 N 4 M150-	6/32 M4 0920137	6/25 M5 0920138	6/22 M8 0920139	6/15 M9 0920141	8/12 M10 0927031	6/29 FK 4D 0927032
29	LT 6/15 N 4 M150-	6/45 M4 0920143	6/29 M8 0920144	6/20 M9 0920145	8/13 M10 0920146	6/45 FK 4D 0927033	6/15 FK 4E 0927034
40	LT 8/18 N 4 M150-	6/51 M4 0920148	6/36 M8 0920149	6/22 M9 0920151	6/22 M9 0920152	6/51 FK 4D 0927035	6/36 FK 4E 0927036
63	LT 8/21 N 4 M150-	6/60 M5 0920155	6/45 M8 0920156	6/29 M9 0920157	8/22 M10 0920158	6/60 FK 4D 0927037	6/45 FK 4E 0927038
80	LT 12/25 N 4 M150-	8/85 M4 0920162	8/57 M8 0920163	8/36 M9 0920164	8/25 M10 0920165	8/76 FK 4D 0927039	8/57 FK 4E 0927040
111	LT 15/30 N4 M150-	10/94 M5 0920168	10/73 M8 0920169	10/54 M9 0920171	10/38 M10 0920172	10/94 FK 4D 0927041	10/73 FK 4E 0927042
130	LT 12/30 N 4 M150-	10/84 M8 0920175	10/73 M8 0920176	10/38 M10 0920177	10/73 FK 4E 0927043	10/73 FK 4E 0927044	10/54 FK 4F 0927045
159	LT 15/34 N 4 M150-	10/94 M8 0920182	10/65 M9 0920183	10/44 M10 0920184	10/94 FK 4E 0927046	10/94 FK 4E 0927047	10/65 FK 4F 0927048
201	LT 18/38 N 4 M150-	12/95 M6 0920188	12/73 M9 0920189	12/52 M10 0920191	12/95 FK 6D 0927049	12/72 FK 6D 0927050	12/85 FK 4F 0927051
Cable NSHTÖU-J 4 x 50 mm ²		Ø 46,5 mm				Weight: 3,6 kg/m	
48	LT 8/21 N 4 M300-	8/76 M7 0920195	8/36 M9 0920196	8/25 M10 0920197	8/67 FK 4D 0927052	8/50 FK 4E 0927053	8/36 FK 4F 0927054
62	LT 12/25 N 4 M300-	8/85 M5 0920202	8/67 M8 0920203	8/41 M9 0920204	8/32 M10 0927055	8/85 FK 4D 0927056	8/41 FK 6E 0927057
90	LT 15/30 N 4 M300-	10/94 M8 0920208	10/94 M8 0920209	10/65 M9 0920211	10/44 M10 0927058	10/84 FK 4E 0927059	10/65 FK 4F 0927060
111	LT 12/30 N 4 M300-	10/94 M8 0920215	10/65 M9 0920216	10/44 M10 0920217	10/94 FK 4E 0927061	10/65 FK 4F 0927062	10/65 FK 4F 0927063
137	LT 15/34 N 4 M300-	10/73 M9 0920222	10/73 M9 0920223	10/54 M10 0920224	10/73 FK 6E 0927064	10/84 FK 4F 0927065	10/54 FK 6F 0927066
166	LT 18/38 N 4 M300-	12/95 M9 0920228	12/95 M9 0920229	12/85 FK 6E 0926067	12/85 FK 6E 0927068	12/95 FK 4F 0927069	12/95 FK 4F 0927070
214	LT 18/41 N 4 M300-	12/73 M10 0920235	12/73 M10 0920236	12/72 FK 6F 0927071	12/72 FK 6F 0927072	12/72 FK 6F 0927073	12/85 FK 4G 0927074
Cable NSHTÖU-J 4 x 70 mm ²		Ø 51 mm				Weight: 4,6 kg/m	
57	LT 12/25 N 4 M300-	10/94 M5 0920242	10/54 M9 0920243	10/38 M10 0920244	10/73 FK 4E 0927075	10/73 FK 4E 0927076	10/54 FK 4F 0927077
83	LT 15/30 N 4 M300-	10/94 M6 0920248	10/73 M9 0920249	10/54 M10 0920251	10/94 FK 6D 0927078	10/73 FK 4F 0927079	10/73 FK 4F 0927080
97	LT 12/30 N 4 M300-	10/94 M6 0920255	10/54 M10 0920256	10/99 FK 6D 0927081	10/73 FK 6E 0927082	10/73 FK 4F 0927083	10/54 FK 4G 0927084

REEL SELECTION CHART

Monospiral wrap, shaft gear, horizontal payout

Applications

1 2



Cable NSHTÖU-J 4 x 70 mm ²		Ø 51 mm				Weight: 4,6 kg/m	
active length [m]	Reel Type	12 m/min.	20 m/min.	30 m/min.	40 m/min.	60 m/min.	80 m/min.
122	LT 15/34 N 4 M300-	10/94 M9 0920262	10/65 M10 0920263	12/85 FK 6E 0927085	12/85 FK 6E 0927086	12/95 FK 4F 0927087	12/72 FK 4G 0927088
148	LT 18/38 N 4 M300-	12/85 M10 0920268	12/85 M10 0920269	12/72 FK 6F 0927089	12/72 FK 6F 0927090	12/72 FK 6F 0927091	12/85 FK 4G 0927092
184	LT 18/41 N 4 M300-	12/95 M10 0920275	12/95 M10 0920276	12/85 FK 6F 0927093	12/85 FK 6F 0927094	12/85 FK 6F 0927095	12/95 FK 4G 0927096
236	LT 18/45 N 4 M300-	14/59 M11 0927097	14/59 M11 0927098	14/78 FK 6G 0927099	14/78 FK 6G 0927100	14/78 FK 4H 0929101	14/78 FK 4H 0927102
Cable NSHTÖU-J 4 x 95 mm ²		Ø 58,5 mm				Weight: 6,2 kg/m	
69	LT 15/30 N 4 M300-	12/95 M9 0920288	12/73 M10 0920289	12/95 FK 6E 0927103	12/95 FK 6E 0927104	12/95 FK 4F 0927105	12/72 FK 4G 0927106
85	LT 12/30 N 4 M300-	12/95 M9 0920295	12/73 M10 0920296	12/95 FK 6E 0927107	12/95 FK 4F 0927108	12/72 FK 4G 0927109	12/53 FK 4H 0927110
97	LT 15/34 N 4 M300-	12/85 M10 0920302	12/85 M10 0920303	12/85 FK 6F 0927111	12/85 FK 6F 0927112	12/85 FK 4G 0927113	12/72 FK 4H 0927114
120	LT 18/38 N 4 M300-	12/95 M10 0920308	12/95 M10 0920309	12/95 FK 6F 0927115	12/95 FK 6F 0927116	12/95 FK 4G 0927117	12/95 FK 4G 0927118
168	LT 18/41 N 4 M300-	12/60 M11 0927119	12/60 M11 0927120	12/85 FK 6G 0927121	12/85 FK 6G 0927122	12/95 FK 4H 0927123	12/95 FK 4H 0927124
194	LT 18/45 N 4 M300-	14/66 M11 0927125	14/66 M11 0927126	14/93 FK 6G 0927127	14/93 FK 6G 0927128	14/78 FK 4I 0927129	14/78 FK 4I 0927130
221	LT 20/48 N 4 M300-	14/78 M11 0927131	14/78 M11 0927132	14/78 M11 0927133	14/78 FK 6H 0927134	14/93 FK 4I 0927135	14/93 FK 4I 0927136
Cable NSHTÖU-J 4 x 120 mm ²		Ø 64 mm				Weight: 7,6 kg/m	
62	LT 15/30 N 4 M500-	12/85 M10 0920335	12/85 M10 0920336	12/72 FK 6F 0927137	12/72 FK 6F 0927138	12/72 FK 6F 0927139	12/85 FK 4G 0927140
70	LT 12/30 N 4 M500-	12/85 M10 0920342	12/44 M11 0927141	12/72 FK 6F 0927142	12/72 FK 6F 0927143	12/85 FK 4G 0927144	12/60 FK 4H 0927145
90	LT 15/34 N 4 M500-	12/95 M10 0920348	12/53 M11 0927146	12/95 FK 6F 0927147	12/95 FK 6F 0927148	12/95 FK 4G 0927149	12/85 FK 4H 0927150
113	LT 18/38 N 4 M500-	12/60 M11 0927151	12/60 M11 0927152	12/85 FK 6G 0927153	12/85 FK 6G 0927154	12/95 FK 4H 0927155	12/95 FK 4H 0927156
139	LT 18/41 N 4 M500-	14/78 M11 0927157	14/78 M11 0927158	14/93 FK 6G 0927159	14/93 FK 6G 0927160	14/78 FK 4I 0927161	14/78 FK 4I 0927162
188	LT 18/45 N 4 M500-	14/93 M11 0927163	14/93 M11 0927164	14/93 FK 6H 0927165	14/93 FK 6H 0927166	14/93 FK 4I 0927167	14/93 FK 4I 0927168
229	LT 20/51 N 4 M500-	16/101 M11 0927169	16/101 M11 0927170	16/101 FK 6H 0927171	16/101 FK 6H 0927172	16/80 FK 4K 0927173	16/80 FK 4K 0927174
Cable NSHTÖU-J 24 x 1,5 mm ²		Ø 30,5 mm				Weight: 1,2 kg/m	
19	LT 6/12 N 24 K 60-	6/36 M3 0920382	6/22 M4 0920383	6/17 M5 0920384	6/15 M8 0920385	-	-
38	LT 6/15 N 24 K 60-	6/45 M3 0920387	6/22 M5 0920388	6/20 M8 0920389	6/12 M9 0920391	8/12 M10 0927175	6/36 FK 4D 0927176
56	LT 8/18 N 24 K 60-	6/60 M3 0920393	6/36 M4 0920394	6/25 M8 0920395	6/15 M9 0920396	-	-

Drive system - Torque motor

Drive system - Torque motor with frequency converter



REEL SELECTION CHART

Monospiral wrap, shaft gear, horizontal payout

Applications

1 2

Cable NSHTÖU-J 24 x 1,5 mm ²		Ø 30,5 mm				Weight: 1,2 kg/m	
active length [m]	Reel Type	12 m/min.	20 m/min.	30 m/min.	40 m/min.	60 m/min.	80 m/min.
86	LT 8/21 N 24 K60-	6/45 M4 0920399	6/36 M5 0920401	6/29 M8 0920402	8/19 M9 0920403	8/16 M10 0927177	6/29 FK 4E 0927178
110	LT 12/25 N 24 K60-	8/85 M3 0920406	8/50 M5 0920407	8/36 M8 0920408	8/25 M9 0920409	8/19 M10 0927179	8/50 FK 4D 0927180
154	LT 15/30 N 24 K60-	8/76 M4 0920413	8/57 M5 0920414	8/50 M8 0920415	8/32 M9 0920416	8/25 M10 0927181	8/67 FK 4D 0927182
Cable NSHTÖU-J 12 x 2,5 mm ²		Ø 25,5 mm				Weight: 0,85 kg/m	
25	LT 6/12 N 12 K60-	6/45 M2 0920419	6/20 M4 0920421	6/15 M5 0920422	6/15 M8 0920423	-	-
48	LT 6/15 N 12 K60-	6/45 M3 0920425	6/24 M4 0920426	6/17 M8 0920427	6/17 M8 0920428	-	-
68	LT 8/18 N 12 K60-	6/51 M3 0920431	6/32 M4 0920432	6/29 M7 0920433	6/20 M8 0920434	-	-
104	LT 8/21 N 12 K60-	6/60 M3 0920437	6/32 M5 0920438	8/22 M6 0920439	6/17 M9 0920441	8/13 M10 0927183	6/45 FK 4D 0927184
133	LT 12/25 N12 K60-	8/76 M3 0920444	8/50 M4 0920445	8/32 M8 0920446	8/32 M8 0920447	-	-
181	LT 15/30 N 12 K60-	8/96 M3 0920451	8/67 M4 0920452	8/41 M8 0920453	8/41 M8 0920454	8/22 M10 0927185	8/22 M10 0927186
Cable NSHTÖU-J 18 x 2,5 mm ²		Ø 29,5 mm				Weight: 1,2 kg/m	
19	LT 6/12 N 18 K60-	6/36 M3 0920457	6/22 M4 0920458	6/17 M5 0920459	6/15 M8 0920461	-	-
38	LT 6/15 N 18 K60-	6/45 M3 0920463	6/22 M5 0920464	6/20 M8 0920465	6/12 M9 0920466	8/12 M10 0927187	6/25 FK 4D 0927188
56	LT 8/18 N 18 K60-	6/60 M3 0920468	6/36 M4 0920469	6/22 M8 0920471	6/22 M8 0920472	-	-
85	LT 8/21 N 18 K60-	6/45 M4 0920475	6/36 M5 0920476	6/29 M8 0920477	6/20 M9 0920478	8/13 M10 0927189	6/29 FK 4E 0927190
108	LT 12/25 N 18 K60-	8/85 M3 0920482	8/50 M5 0920483	8/36 M8 0920484	8/22 M9 0920485	8/19 M10 0927191	8/50 FK 4D 0927192
153	LT 15/30 N 18 K60-	8/76 M4 0920488	8/57 M5 0920489	8/50 M8 0920491	8/32 M9 0920492	8/25 M10 0927193	8/67 FK 4D 0927194
176	LT 12/30 N 18 K60-	8/76 M4 0920495	8/50 M8 0920496	8/32 M9 0920497	8/32 M9 0920498	8/67 FK 4D 0927195	8/50 FK 4E 0927196
220	LT 15/34 N 18 K60-	10/94 M4 0920502	10/65 M8 0920503	10/44 M9 0920504	10/30 M10 0920505	10/84 FK 4D 0927197	10/65 FK 4E 0927198
Cable NSHTÖU-J 24 x 2,5 mm ²		Ø 34,5 mm				Weight: 1,65 kg/m	
16	LT 6/12 N 24 K60-	6/45 M3 0920508	6/25 M4 0920509	6/17 M8 0920511	6/17 M8 0920512	-	-
32	LT 6/15 N 24 K60-	6/32 M4 0920514	6/25 M5 0920515	6/22 M8 0920516	6/15 M9 0920517	8/12 M10 0927199	6/29 FK 4D 0927200
48	LT 8/18 N 24 K60-	6/45 M4 0920519	6/32 M5 0920521	6/29 M8 0920522	6/17 M9 0920523	8/13 M10 0927201	6/36 FK 4D 0927202
71	LT 8/21 N 24 K60-	6/51 M4 0920526	6/36 M8 0920527	6/22 M9 0920528	6/22 M9 0920529	8/16 M10 0927203	6/32 FK 4E 0927204

REEL SELECTION CHART

Monospiral wrap, shaft gear, horizontal payout

Applications

1 2



Cable NSHTÖU-J 24 x 2,5 mm ²		Ø 34,5 mm				Weight: 1,65 kg/m	
active length [m]	Reel Type	12 m/min.	20 m/min.	30 m/min.	40 m/min.	60 m/min.	80 m/min.
91	LT 12/25 N 24 K60-	8/67 M4 0920533	8/50 M5 0920534	8/41 M8 0920535	8/28 M9 0920536	8/22 M10 0927205	8/57 FK 4D 0927206
133	LT 15/30 N 24 K60-	8/85 M4 0920539	8/67 M5 0920541	8/57 M8 0920542	8/36 M9 0920543	8/28 M10 0927207	8/76 FK 4D 0927208
149	LT 12/30 N 24 K60-	8/85 M4 0920546	8/57 M8 0920547	8/36 M9 0920548	8/28 M10 0920549	8/76 FK 4D 0927209	8/57 FK 4E 0927210
191	LT 15/34 N 24 K60-	10/94 M5 0920553	10/73 M8 0920554	10/54 M9 0920555	10/38 M10 0920556	10/73 FK 4E 0927211	10/73 FK 4E 0927212
226	LT 18/38 N 24 K60-	12/85 M8 0920559	12/85 M8 0920561	12/60 M9 0920562	12/44 M10 0920563	12/85 FK 4E 0927213	12/85 FK 4E 0927214
Cable NSHTÖU-J 30 x 2,5 mm ²		Ø 36,5 mm				Weight: 1,90 kg/m	
13	LT 6/12 N 30 K60-	6/45 M3 0920566	6/29 M4 0920567	6/17 M8 0920568	6/17 M8 0920569	-	-
32	LT 6/15 N 30 K60-	6/36 M4 0920572	6/29 M5 0920573	6/17 M9 0920574	6/17 M9 0920575	8/12 M10 0927215	6/32 FK 4D 0927216
44	LT 8/18 N 30 K60-	6/45 M4 0920577	6/36 M5 0920578	6/29 M8 0920579	6/20 M9 0920581	8/16 M10 0927217	6/45 FK 4D 0927218
67	LT 8/21 N 30 K60-	6/60 M4 0920584	6/53 M7 0920585	6/25 M9 0920586	8/16 M10 0920587	8/57 FK 4D 0927219	6/36 FK 4E 0927220
86	LT 12/25 N 30 K60-	8/67 M7 0920591	8/67 M7 0920592	8/28 M9 0920593	8/28 M9 0920594	8/22 M10 0927221	8/50 FK 4E 0927222
126	LT 15/30 n 30 K60-	8/96 M4 0920597	8/85 M7 0920598	8/41 M9 0920599	8/41 M9 0920601	8/85 FK 4D 0927223	8/57 FK 4E 0927224
143	LT 12/30 N 30 K60-	8/76 M5 0920604	8/67 M8 0920605	8/41 M9 0920606	8/28 M10 0920607	8/85 FK 4D 0927225	8/41 FK 6E 0927226
174	LT 15/34 N 30 K60-	10/94 M5 0920611	10/84 M8 0920612	10/54 M9 0920613	10/38 M10 0920614	10/84 FK 4E 0927227	10/54 FK 4F 0927228
219	LT 18/38 N 30 K60-	12/95 M8 0920617	12/95 M8 0920618	12/60 M9 0920619	12/44 M10 0920621	12/45 FK 4E 0927229	12/60 FK 6E 0927230
Cable NSHTÖU-J 36 x 2,5 mm ²		Ø 40 mm				Weight: 2,20 kg/m	
13	LT 6/12 N 36 P25-	6/29 M4 0920624	6/29 M4 0920625	6/20 M8 0920626	6/15 M9 0920627	-	-
29	LT 6/15 N 36 P25-	6/45 M4 0920629	6/25 M8 0920631	6/17 M9 0920632	6/17 M9 0920633	6/36 FK 4D 0927231	6/25 FK 4E 0927332
40	LT 8/18 N 36 P25-	6/51 M4 0920635	6/40 M5 0920636	6/32 M8 0920637	6/22 M9 0920638	8/16 M10 0927233	6/45 FK 4D 0927234
63	LT 8/21 N 36 P25-	6/60 M4 0920642	6/45 M8 0920643	6/25 M9 0920644	8/19 M10 0920645	6/51 FK 4D 0927235	6/45 FK 4E 0927236
73	LT 12/25 N 36 P25-	8/76 M4 0920648	8/72 M7 0920649	8/32 M9 0920651	8/32 M9 0920652	8/25 M10 0927237	8/50 FK 4E 0927238
112	LT 15/30 N 36 P25-	10/105 M4 0920655	10/65 M8 0920656	10/44 M9 0920657	10/44 M9 0920658	8/85 FK 4D 0927239	8/67 FK 4E 0927240
131	LT 12/30 N 36 P25-	10/105 M4 0920662	10/65 M8 0920663	10/44 M9 0920664	10/31 M10 0920665	8/67 FK 4E 0927241	8/50 FK 4F 0927242
160	LT 15/34 N 36 P25-	10/84 M8 0920668	10/84 M8 0920669	10/54 M9 0920671	10/44 M10 0927243	10/84 FK 4E 0927244	10/65 FK 4F 0927245
191	LT 18/38 N 36 P25-	12/85 M6 0920675	12/73 M9 0920676	12/53 M10 0920677	12/53 M10 0927246	12/95 FK 4E 0927247	12/95 FK 4E 0927248
230	LT 18/41 N 36 P25-	12/95 M6 0920682	12/73 M9 0920683	12/53 M10 0920684	12/95 FK 6D 0927249	12/72 FK 6E 0927250	12/85 FK 4F 0927251

Drive system - Torque motor

Drive system - Torque motor with frequency converter



REEL DIMENSIONAL DATA for reel selection chart, pages 9-13

Monospiral wrap, shaft gear

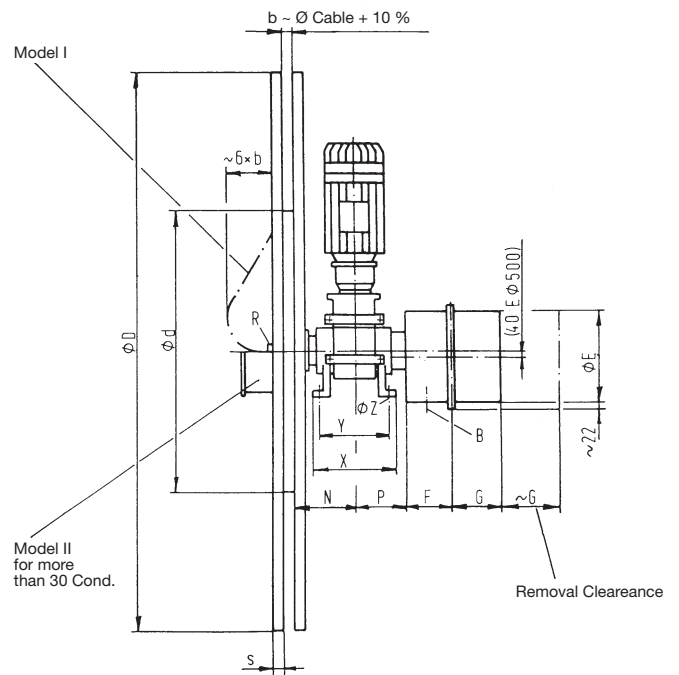
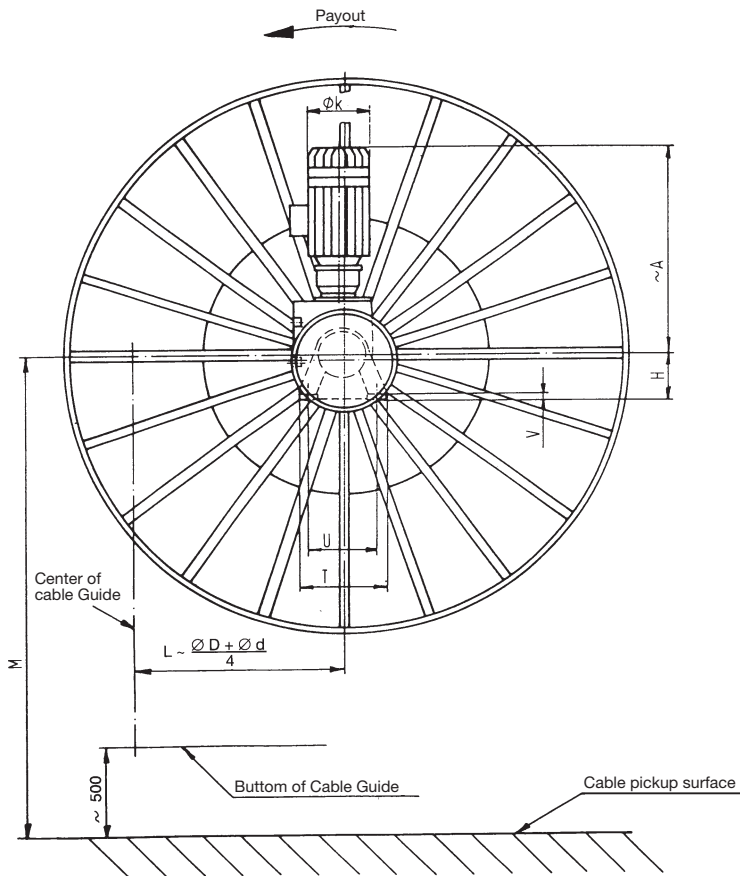

B = Cable entrance to brushes
R = Cable entrance to rings

Type	A	Ø d	Ø D	H	Ø k	M	N	P	s	T	U	V	X	Y	Ø Z	~ kg
LT 6/12N ... - 6	945	600	1200	140	250	1500*	229	161	20	250	210	20	250	220	13	300
- 8	855			175	246		255	187		300	240	25	300	260	17	350
LT 6/15N ... - 6	945	600	1500	140	250	1500*	229	161	20	250	210	20	250	220	13	310
- 8	1055			175	274		255	187		300	240	25	300	260	17	420
LT 8/18N ... - 6	945	800	1800	140	250	1500*	229	161	30	250	210	20	250	220	13	320
- 8	1100			175	320		255	187		300	240	25	300	260	17	460
LT 8/21N ... - 6	945	800	2100	140	250	2000*	229	161	40	250	210	20	250	220	13	360
- 8	1055			175	274		255	187		300	240	25	300	260	17	400
LT12/25N ... - 8	1055	1200	2500	175	274	2000*	255	187	40	300	240	25	300	260	17	480
-10	1210			210	380		310	287		380	310	30	355	300	22	640
- 8	1185			175	380		255	187		300	240	25	300	260	17	660
LT12/30N ... -10	1460	1200	3000	210		3300	310	287	60	380	310	30	355	300	22	910
-12	1505			250	470		355	332		450	360	35	450	380	26	1348
- 8	1185			175	380		255	187		300	240	25	300	260	17	610
LT15/30N ... -10	1460	1500	3000	210		3300	310	287	50	380	310	30	355	300	22	800
-12	1505			250	470		355	332		450	360	35	450	380	26	1170
LT15/34N ... -10	1460	1500	3400	210	470	3450	310	287	60	380	310	30	355	300	22	1350
-12	1535			250			355	332		450	360	35	450	380	26	1500
LT18/38N ... -12	1505	1800	3800	250	470	3650	355	332	70	450	360	35	450	380	26	1600
LT18/41N ... -12	1535	1800	4150	250	470	3850	355	332	80	450	360	35	450	380	26	1780

REEL DIMENSIONAL DATA for reel selection chart, page 9-13

Monospiral wrap, shaft gear

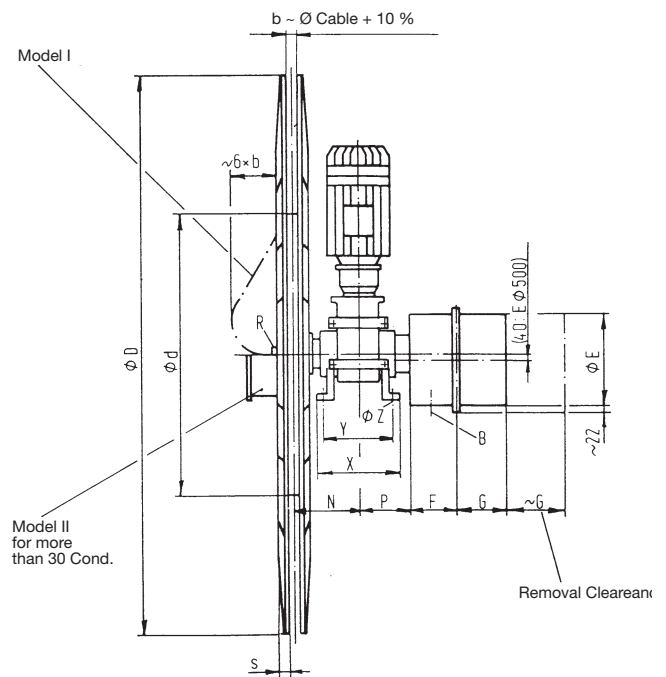
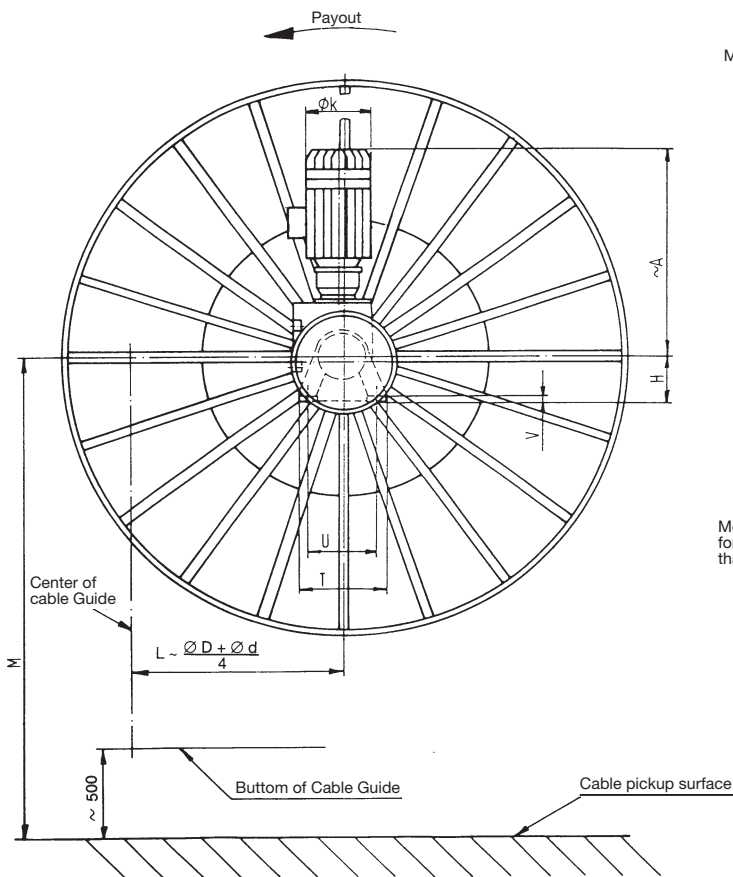

B = Cable entrance to brushes
R = Cable entrance to rings

Type	A	Ø d	Ø D	H	Ø k	M	N	P	s	T	U	V	X	Y	Ø Z	≈ kg
LT 18/45N . . . -14	1800	1800	4500	300	470	4000	480	371	135	550	470	40	540	450	33	2250
LT 20/48N . . . -14	1800	2000	4800	300	470	4150	480	371	135	550	470	40	540	450	33	2270
LT 20/51N . . . -16	1850	2000	5100	350	470	4300	532	410	150	640	520	45	640	540	39	3125

Dimensional data of collector assembly hoods p. drawings pages 14 and 15

SRK-Type	E	F	G
4 M 60	Ø 340	153	153
7 K 60			353
12 K 60			
18 K 60			
24 K 60			
30 K 60			353
36 P 25			
4 M150	Ø 500	203	153
4 M300			203
4 M500			



REEL SELECTION CHART

Monospiral wrap, shaft gear, horizontal payout

Applications

1 2

Cable NTSCGEWÖU (SM-R) 6 KV 3 x 25 + 3 x 25/3 mm ² Ø 48,1 mm Weight: 3,15 kg/m							
active length [m]	Reel Type	12 m/min.	20 m/min.	30 m/min.	40 m/min.	50 m/min.	60 m/min.
124	LT 15/34 H 4 K200-	10/94 R9 0927252	10/73 R9 0927253	10/54 R10 0927254	10/94 FP 6D 0927255	10/73 FP 6E 0927256	10/73 FP 4F 0927257
150	LT 18/38 H 4 K200-	12/85 R9 0927258	12/85 R9 0927259	12/60 R10 0927260	12/85 FP 6E 0927261	12/85 FP 6E 0927262	12/85 FP 4F 0927263
198	LT 18/41 H 4 K200-	12/72 R10 0927264	12/72 R10 0927265	12/72 R10 0927266	12/95 FP 6E 0927267	12/72 FP 6F 0927268	12/72 FP 4G 0927269
237	LT 18/45 H 4 K200-	14/93 R10 0927270	14/93 R10 0927271	14/78 FP 6F 0927272	14/78 FP 6F 0927273	14/78 FP 6F 0927274	14/93 FP 4G 0927275
267	LT 20/48 H 4 K200	14/93 R10 0927276	14/93 R10 0927277	14/93 FP 6F 0927278	14/93 FP 6F 0927279	14/93 FP 6F 0927280	14/93 FP 4G 0927281
Cable NTSCGEWÖU 6 KV 3 x 35 + 3 x 35/3 mm ² Ø 53 mm Weight: 3,8 kg/m							
107	LT 15/34 H 4 K200-	10/84 R9 0921034	10/84 R9 0921035	10/54 R10 0921036	10/84 FK 6E 0927282	10/84 FP 4F 0927283	10/84 FP 4F 0927284
131	LT 18/38 H 4 K200-	12/95 R9 0921041	12/95 R9 0921042	12/72 R10 0927285	12/95 FK 6E 0927286	12/95 FK 4F 0927287	12/95 FP 4F 0927288
179	LT 18/41 H 4 K200-	12/85 R10 0921047	12/85 R10 0921048	12/44 R11 0927289	12/72 FK 6F 0927290	12/72 FP 6F 0927291	12/85 FP 4G 0927292
219	LT 18/45 H 4 K200-	14/93 R10 0921054	14/93 R10 0921055	14/93 FP 6F 0927293	14/93 FP 6F 0927294	14/93 FP 4G 0927295	14/93 FP 4G 0927296
247	LT 20/48 H 4 K200-	14/52 R11 0927297	14/59 R11 0927298	14/93 FP 6F 0927299	14/93 FP 6F 0927300	14/93 FP 6F 0927301	14/78 FP 4H 0927302
277	LT 20/51 H 4 K200-	16/60 R11 0927303	16/60 R11 0927304	16/101 FP 6F 0927305	16/101 FP 6F 0927306	16/85 FP 4H 0927307	16/85 FP 4H 0927308
Cable NTSCGEWÖU (SM-R) 10 KV 3 x 25 + 3 x 25/3 mm ² Ø 49,9 mm Weight: 3,52 kg/m							
115	LT 15/34 H 4 K200-	10/84 R9 0927309	10/84 R9 0927310	10/65 R10 0927311	10/94 FP 6D 0927312	10/73 FP 6E 0927313	10/73 FP 4F 0927314
141	LT 18/38 H 4 K200-	12/95 R9 0927315	12/95 R9 0927316	12/72 R 10 0927317	12/85 FP 6E 0927318	12/85 FP 6E 0927319	12/95 FP 4F 0927320
188	LT 18/41 H 4 K200-	12/85 R10 0927321	12/85 R10 0927322	12/39 R11 0927323	12/72 FP 6F 0927324	12/85 FP 4G 0927325	12/85 FP 4G 0927326
228	LT 18/45 H 4 K200-	14/93 R10 0927327	14/93 R10 0927328	14/47 R11 0927329	14/78 FP 6F 0927330	14/78 FP 6F 0927331	14/93 FP 4G 0927332
256	LT 20/48 H 4 K200-	14/53 R11 0927333	14/52 R11 0927334	14/93 FP 6F 0927335	14/93 FP 6F 0927336	14/93 FP 6F 0927337	14/78 FP 4H 0927338
Cable NTSCGEWÖU 10 KV 3 x 35 + 3 x 35/3 mm ² Ø 53,5 mm Weight: 3,95 kg/m							
108	LT 15/34 H 4 K200-	10/84 R9 0921107	10/84 R9 0921108	10/65 R10 0927339	10/84 FK 6E 0927340	10/84 FP 4F 0927341	10/84 FP 4F 0927342
132	LT 18/38 H 4 K200-	12/95 R9 0921114	12/95 R9 0921115	12/72 R10 0927343	12/95 FP 6F 0927344	12/95 FK 4F 0927345	12/95 FP 4F 0927346
168	LT 18/41 H 4 K200-	12/85 R10 0921121	12/85 R10 0921122	12/85 FP 6F 0927347	12/85 FP 6F 0927348	12/85 FP 6F 0927349	12/85 FP 4G 0927350
220	LT 18/45 H 4 K200-	14/93 R10 0921127	14/93 R10 0921128	14/93 FP 6F 0927351	14/93 FP 6F 0927352	14/78 FP 4H 0927353	14/78 FP 4H 0927354
248	LT 20/48 H 4 K200-	14/54 R11 0927355	14/59 R11 0927356	14/59 R11 0927357	14/78 FP 6G 0927358	14/93 FP 4H 0927359	14/93 FP 4H 0927360
278	LT 20/51 H 4 K200-	16/60 R11 0927361	16/60 R11 0927362	16/60 R11 0927363	16/80 FP 6G 0927364	16/101 FP 4H 0927365	16/101 FP 4H 0927367

REEL DIMENSIONAL DATA for selection chart page 16

Monospiral wrap, shaft gear

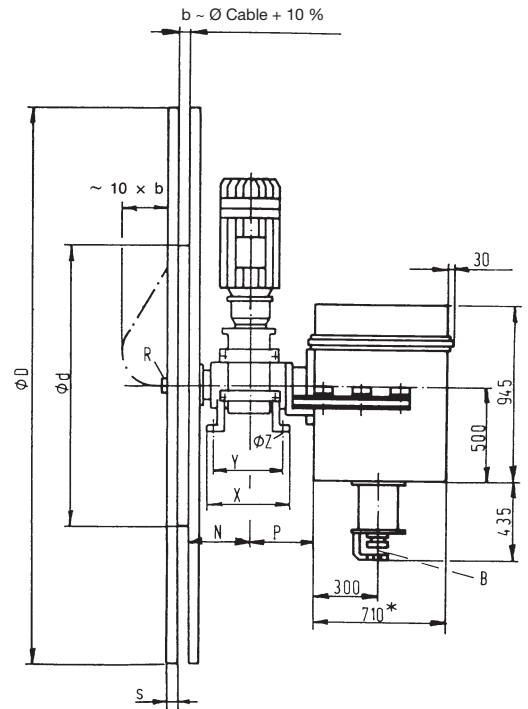
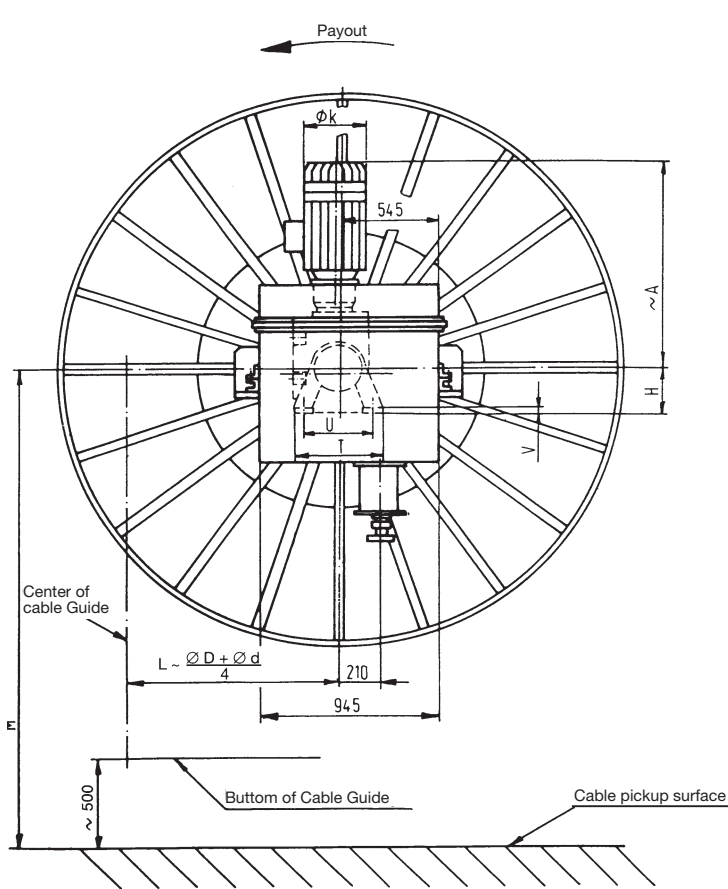

B = Cable entrance to brushes
R = Cable entrance to rings

Type	A	Ø d	Ø D	H	Ø k	M	N	P	s	T	U	V	X	Y	Ø Z	= kg
LT 15/34H ...-10	1460	1500	3400	210	380	3450	310	287	60	380	310	30	355	300	22	1310
LT 18/38H ...-12	1460	1800	3800	250	380	3650	355	332	70	450	360	35	450	380	26	1540
LT 18/41H ...-12	1505	1800	4150	250	380	3850	355	332	80	450	360	35	450	380	26	1720
LT 18/45H ...-14	1550	1800	4500	300	380	4000	500	371	80	550	470	40	540	450	33	2200
LT 20/48H ...-14	1550	2000	4800	300	470	4150	455	371	135	550	470	40	540	450	33	2570
LT 20/51H ...-16	1600	2000	5100	350	470	4300	505	410	135	640	520	45	640	540	39	3250

All dimensions in mm

* This dimension increases when using optic data links.



VAHLE LT-REELS IN ACTION

Random wrap, chain transmission, horizontal payout

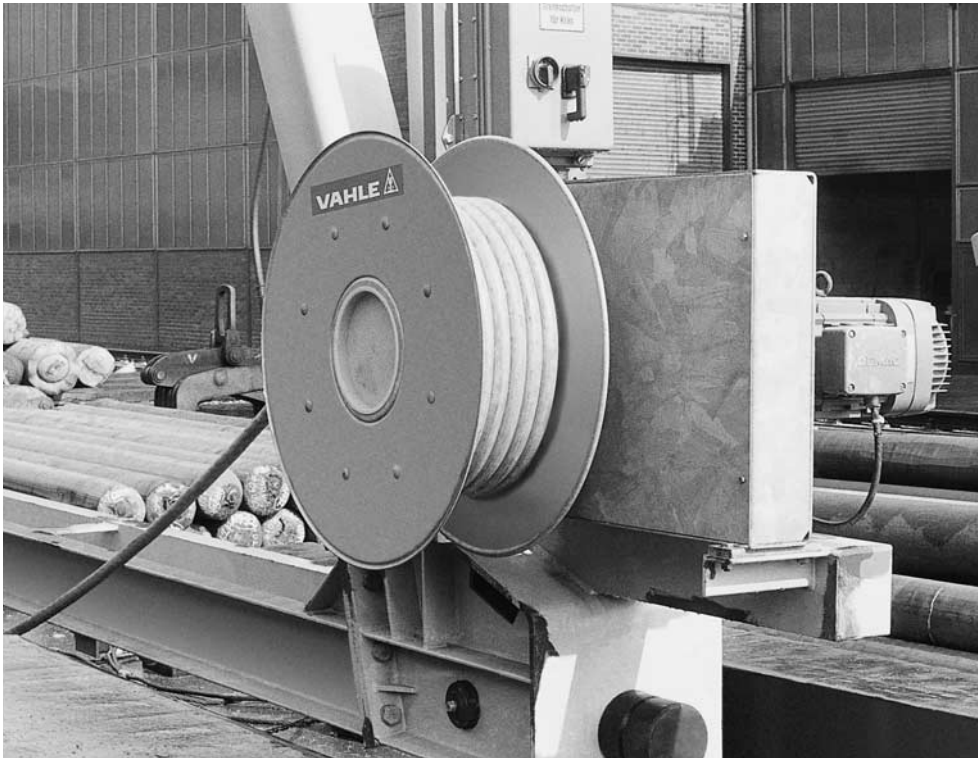

Type LT 50 N 4 M 150-K/8 M 4
on a Portal Yard crane

Type LT 38 N 4 M 60-K/7 M 4
on a loading bridge

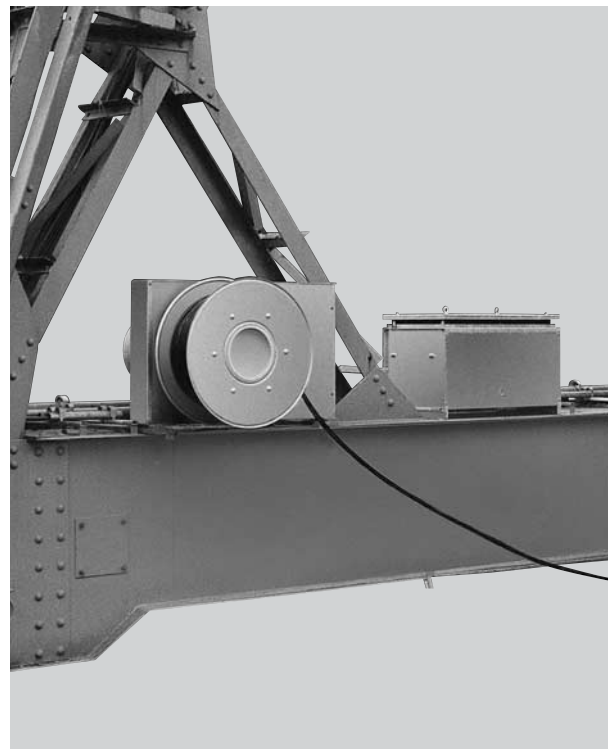

REEL SELECTION CHART

Random wrap, chain transmission, horizontal payout

Application

1



Cable NSHTÖU-J 4 x 2,5 mm ²			Ø 16,5 mm				Weight: 0,33 kg/m		
active length [m]	LZ*	Reel Type	12 m/min.	20 m/min.	30 m/min.	40 m/min.	50 m/min.	63 m/min.	
32	3	LT 28 N 4 M60-	K/8 M2 0922001	K/8 M2 0922002	K/6 M3 0922003	K/6 M 3 0922004	K/4 M4 0922005	K/3 M5 0922006	
84	5	LT 38 N 4 M 60-	K/9 M3 0922007	K/9 M3 0922008	K/9 M3 0922009	K/5 M4 0922011	K/5 M4 0922012	K/4 M5 0922013	
124	5	LT 50 N 4 M 60-	K/24 M1 0922014	K/7 M4 0922015	K/7 M4 0922016	K/7 M4 0922017	K/7 M4 0922018	K/5 M5 0922019	
Cable NSHTÖU-J 4 x 4 mm ²			Ø 19,5 mm				Weight: 0,47 kg/m		
26	3	LT 28 N 4 M60-	K/9 M2 0922021	K/9 M2 0922022	K/6 M3 0922023	K/6 M3 0922024	K/4 M4 0922025	K/3 M5 0922026	
72	5	LT 38 N 4 M60-	K/9 M3 0922027	K/9 M3 0922028	K/9 M3 0922029	K/96 M4 0922031	K/6 M4 0922032	K/5 M5 0922033	
108	5	LT 50 N 4 M60-	KG/24 M1 0922034	K/7 M4 0922035	K/7 M4 0922036	K/7 M4 0922037	K/7 M4 0922038	K/6 M5 0922039	
Cable NSHTÖU-J 4 x 6 mm ²			Ø 21 mm				Weight: 0,6 kg/m		
14	2	LT 28 N 4 M60-	K/8 M2 0922041	K/8 M2 0922042	K/6 M3 0922043	K/6 M3 0922044	K/3 M4 0922045	K/3 M5 0922046	
49	4	LT 38 N 4 M60-	K/9 M3 0922047	K/9 M3 0922048	K/9 M3 0922049	K/6 M4 0922051	K/6 M4 0922052	K/4 M5 0922053	
100	5	LT 50 N 4 M60-	KG/24 M1 0922054	K/7 M4 0922055	K/7 M4 0922056	K/7 M4 0922057	K/7 M4 0922058	K/6 M5 0922059	
139	5	LT 50. 1N 4 M60-	KG/24 M1 0922061	K/7 M4 0922062	K/7 M4 0922063	K/7 M4 0922064	K/7 M4 0922065	K/6 M5 0922066	
Cable NSHTÖU-J 4 x 10 mm ²			Ø 25,5 mm				Weight: 0,95 kg/m		
31	3	LT 38 N 4 M60-	K/8 M3 0922067	K/8 M3 0922068	K/8 M3 0922069	K/6 M4 0922071	K/6 M4 0922072	K/4 M5 0922073	
64	4	LT 50 N 4 M60-	KG/24 M1 0922074	K/7 M4 0922075	K/7 M4 0922076	K/7 M4 0922077	K/7 M4 0922078	K/6 M5 0922079	
87	4	LT 50. 1N 4 M60-	KG/29 M1 0922081	K/9 M4 0922082	K/9 M4 0922083	K/9 M4 0922084	K/7 M5 0922085	K/7 M5 0922086	
150	5	LT 70 N 4 M60-	KG/46 M1 0922087	KG/30 M2 0922088	KG/14 M4 0922089	KG/14 M4 0922091	K/8 M6 0922092	K/6 M5 0922093	
Cable NSHTÖU-J 4 x 16 mm ²			Ø 30 mm				Weight: 1,4 kg/m		
23	3	LT 38 N 4 M150-	K/9 M3 0922094	K/9 M3 0922095	K/9 M3 0922096	K/6 M4 0922097	K/6 M4 0922098	K/4 M5 0922099	
50	4	LT 50 N 4 M150-	KG/31 M1 0922101	K/9 M4 0922102	K/9 M4 0922103	K/9 M4 0922104	K/7 M5 0922105	K/6 M8 0922106	
80	4	LT 50. 1N 4 M150-	KG/35 M1 0922107	K/23 M2 0922108	K/8 M5 0922109	K/9 M5 0922111	K/8 M5 0922112	K/7 M8 0922113	
140	5	LT 70 N 4 M150-	KG/40 M2 0922114	KG/29 M3 0922115	KG/19 M4 0922116	K/8 M9 0922117	K/8 M9 0922118	K/8 M9 0922119	

* LZ = No. of cable layers



REEL SELECTION CHART

Random wrap, horizontal payout

Application

1

Cable NSHTÖU-J 4 x 25 mm ²			Ø 35 mm			Weight: 1,90 kg/m		
active length [m]	LZ*	Reel Type	12 m/min.	20 m/min.	30 m/min.	40 m/min.	50 m/min.	63 m/min.
30	3	LT 50 N 4 M150-	KG/33 M1 0922121	KG/22 M2 0922122	K/8 M5 0922123	K/8 M5 0922124	K/8 M5 0922125	K/7 M8 0922126
47	3	LT 50. 1N 4 M150-	KG/35 M1 0922127	KG/22 M2 0922128	K/8 M5 0922129	K/8 M5 0922131	K/8 M5 0922132	K/7 M8 0922133
118	5	LT 70 N 4 M150-	KG/43 M2 0922134	KG/31 M3 0922135	KG/20 M4 0922136	K/8 M9 0922137	K/8 M9 0922138	K/8 M9 0922139
Cable NSHTÖU-J 4 x 35 mm ²			Ø 39,5 mm			Weight: 2,60 kg/m		
42	3	LT 50. 1N 4 M150-	KG/26 M3 0922141	KG/16 M4 0922142	K/9 M6 0922143	K/9 M6 0922144	K/7 M9 0922145	K/5 M10 0922146
80	4	LT 70 N 4 M150-	KG/41 M3 0922147	KG/26 M4 0922148	K/8 M10 0922149	K/8 M10 0922151	K/8 M10 0922152	K/8 M10 0922153
Cable NSHTÖU-J 7 x 1,5 mm ²			Ø 19 mm			Weight: 0,43 kg/m		
26	3	LT 28 N 7 K60-	K/9 M2 0922154	K/9 M2 0922155	K/6 M3 0922156	K/4 M4 0922157	K/4 M4 0922158	K/3 M5 0922159
72	5	LT 38 N 7 K60-	K/9 M3 0922161	K/9 M3 0922162	K/9 M3 0922163	K/6 M4 0922164	K/5 M5 0922165	K/3 M6 0922166
107	5	LT 50 N 7 K60-	KG/24 M1 0922167	K/7 M4 0922168	K/7 M4 0922169	K/7 M4 0922171	K/7 M4 0922172	K/6 M5 0922173
154	5	LT 50. 1N 7 K60-	KG/24 M1 0922174	K/7 M4 0922175	K/7 M4 0922176	K/7 M4 0922177	K/7 M4 0922178	K/6 M5 0922179
Cable NSHTÖU-J 12 x 1,5 mm ²			Ø 22 mm			Weight: 0,60 kg/m		
14	2	LT 28 N 12 K60-	K/8 M2 0922181	K/8 M2 0922182	K/6 M3 0922183	K/4 M4 0922184	K/4 M4 0922185	K/3 M5 0922186
49	4	LT 38 N 12 K60-	K/9 M3 0922187	K/9 M3 0922188	K/9 M3 0922189	K/6 M4 0922191	K/5 M5 0922192	K/5 M5 0922193
92	5	LT 50 N 12 K60-	KG/27 M1 0922194	K/8 M4 0922195	K/8 M4 0922196	K/8 M4 0922197	K/6 M5 0922198	K/5 M8 0922199
139	5	LT 50. 1N 12 K60-	KG/29 M1 0922201	K/8 M4 0922202	K/8 M4 0922203	K/8 M4 0922204	K/7 M5 0922205	K/5 M9 0922206
Cable NSHTÖU-J 24 x 1,5 mm ²			Ø 30,5 mm			Weight: 1,20 kg/m		
24	3	LT 38 N 24 K60-	K/8 M4 0922207	K/8 M4 0922208	K/8 M4 0922209	K/6 M5 0922211	K/5 M8 0922212	K/4 M6 0922213
50	4	LT 50 N 24 K60-	KG/24 M2 0922214	KG/17 M3 0922215	K/9 M5 0922216	K/9 M5 0922217	K/7 M8 0922218	K/6 M6 0922219
74	4	LT 50. 1N 24 K60-	KG/25 M2 0922221	KG/17 M3 0922222	K/9 M5 0922223	K/9 M5 0922224	K/7 M8 0922225	K/5 M9 0922226
128	5	LT 70 N 24 K60-	KG/36 M2 0922227	KG/26 M3 0922228	KG/16 M4 0922229	K/9 M6 0922231	K/9 M6 0922232	K/7 M9 0922233

* LZ = No. of cable layers

REEL SELECTION CHART

Random wrap, chain transmission, horizontal payout

Application **1**



Cable NSHTÖU-J 7 x 2,5 mm ²			Ø 21,5 mm				Weight: 0,56 kg/m		
active length [m]	LZ*	Reel Type	12 m/min.	20 m/min.	30 m/min.	40 m/min.	50 m/min.	63 m/min.	
14	2	LT 28 N 7 K60-	K/8 M2 0922234	K/8 M2 0922235	K/6 M3 0922236	K/4 M4 0922237	K/4 M4 0922238	K/3 M5 0922239	
49	4	LT 38 N 7 K60-	K/9 M3 0922241	K/9 M3 0922242	K/9 M3 0922243	K/6 M4 0922244	K/6 M4 0922245	K/4 M5 0922246	
92	5	LT 50 N 7 K60-	KG/26 M1 0922247	K/8 M4 0922248	K/8 M4 0922249	K/8 M4 0922251	K/6 M5 0922252	K/6 M5 0922253	
139	5	LT 50. 1N 7 K60-	KG/27 M1 0922254	K/8 M4 0922255	K/8 M4 0922256	K/8 M4 0922257	K/6 M5 0922258	K/5 M8 0922259	
Cable NSHTÖU-J 12 x 2,5 mm ²			Ø 25,5 mm				Weight: 0,85 kg/m		
31	3	LT 38 N 12 K60-	KG/22 M1 0922261	K/6 M4 0922262	K/6 M4 0922263	K/6 M4 0922264	K/5 M5 0922265	K/4 M8 0922266	
64	4	LT 50 N 12 K60-	KG/30 M1 0922267	K/9 M4 0922268	K/9 M4 0922269	K/9 M4 0922271	K/7 M5 0922272	K/6 M8 0922273	
87	4	LT 50. 1N 12 K60-	KG/30 M1 0922274	K/9 M4 0922275	K/9 M4 0922276	K/9 M4 0922277	K/7 M5 0922278	K/6 M8 0922279	
150	5	LT 70 N 12 K60-	KG/46 M1 0922281	KG/21 M3 0922282	KG/13 M4 0922283	KG/13 M4 0922284	K/9 M8 0922285	K/7 M6 0922286	
Cable NSHTÖU-J 18 x 2,5 mm ²			Ø 29,5 mm				Weight: 1,20 kg/m		
27	3	LT 38 N 18 K60-	K/8 M4 0922287	K/8 M4 0922288	K/8 M4 0922289	K/6 M5 0922291	K/5 M8 0922292	K/4 M6 0922293	
58	4	LT 50 N 18 K60-	KG/24 M2 0922294	KG/17 M3 0922295	K/9 M5 0922296	K/9 M5 0922297	K/7 M8 0922298	K/6 M6 0922299	
81	4	LT 50. 1N 18 K60-	KG/24 M2 0922301	KG/17 M3 0922302	K/9 M5 0922303	K/9 M5 0922304	K/7 M8 0922305	K/6 M6 0922306	
141	5	LT 70 N 18 K60-	KG/36 M2 0922307	KG/26 M3 0922308	KG/16 M4 0922309	K/9 M6 0922311	K/9 M6 0922312	K/7 M9 0922313	
Cable NSHTÖU-J 24 x 2,5 mm ²			Ø 34,5 mm				Weight: 1,65 kg/m		
30	3	LT 50 N 24 K60-	KG/28 M2 0922314	KG/19 M3 0922315	KG/13 M4 0922316	K/8 M8 0922317	K/8 M8 0922318	K/5 M9 0922319	
47	3	LT 50. 1N 24 K60-	KG/28 M2 0922321	KG/19 M3 0922322	KG/13 M4 0922323	K/8 M8 0922324	K/7 M6 0922325	K/5 M9 0922326	
118	5	LT 70 N 24 K60-	KG/43 M2 0922327	KG/20 M4 0922328	K/8 M9 0922329	K/8 M9 0922331	K/8 M9 0922332	K/8 M9 0922333	
Cable NSHTÖU-J 30 x 2,5 mm ²			Ø 36,5 mm				Weight: 1,90 kg/m		
30	3	LT 50 N 30 K60-	KG/30 M2 0922334	KG/13 M4 0922335	KG/13 M4 0922336	K/9 M8 0922337	K/8 M6 0922338	K/6 M9 0922339	
47	3	LT 50. 1N 30 K60-	KG/30 M2 0922341	KG/13 M4 0922342	KG/13 M4 0922343	K/9 M8 0922344	K/8 M6 0922345	K/6 M9 0922346	
118	5	LT 70 N 30 K60-	KG/35 M3 0922347	KG/23 M4 0922348	K/9 M9 0922349	K/9 M9 0922351	K/9 M9 0922352	K/9 M9 0922353	

* LZ = No. of cable layers



VAHLE MOTOR-DRIVEN REELS

Random wrap, shaft gear, horizontal payout



Type LT 28 N 4 M 60-6/12 M 1

Type LT 50 N 4 M 150-6/25 M 5

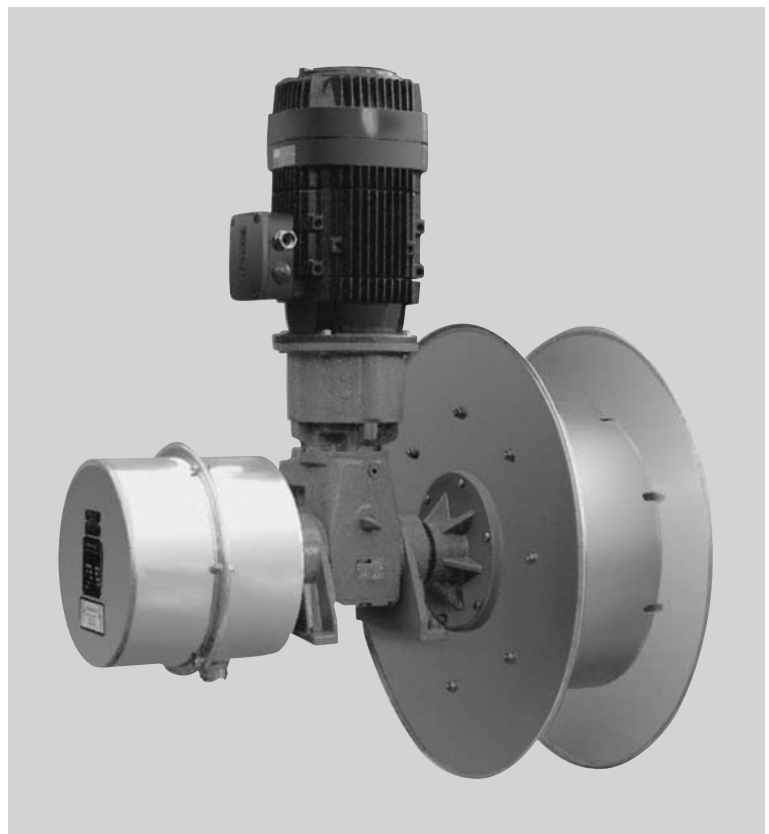

REEL SELECTION CHART

Random wrap, shaft gear, horizontal payout

Application **1**



Cable NSHTÖU-J 4 x 2,5 mm ²			Ø 16,5 mm				Weight: 0,33 kg/m		
active length [m]	LZ*	Reel Type	12 m/min.	20 m/min.	30 m/min.	40 m/min.	50 m/min.	63 m/min.	
32	3	LT 28 N 4 M60-	6/15 M1 0923001	6/10 M2 0923002	6/7 M3 0923003	-	-	-	
84	5	LT 38 N 4 M60-	6/20 M1 0923004	6/15 M2 0923005	6/10 M3 0923006	6/7 M4 0923007	-	-	
124	5	LT 50 N 4 M60-	6/25 M1 0923008	6/17 M2 0923009	6/12 M3 0923011	6/10 M4 0923012	6/7 M5 0923013	-	
Cable NSHTÖUu-J 4 x 4 mm ²			Ø 19,5 mm				Weight: 0,47 kg/m		
26	3	LT 28 N 4 M60-	6/15 M1 0923014	6/10 M2 0923015	6/7 M3 0923016	-	-	-	
72	5	LT 38 N 4 M60-	6/22 M1 0923017	6/15 M2 0923018	6/10 M3 0923019	6/7 M4 0923021	-	-	
108	5	LT 50 N 4 M60-	6/25 M1 0923022	6/17 M2 0923023	6/12 M3 0923024	6/10 M4 0923025	6/7 M5 0923026	-	
Cable NSHTÖU-J 4 x 6 mm ²			Ø 21 mm				Weight: 0,60 kg/m		
14	2	LT 28 N 4 M60-	6/15 M1 0923027	6/10 M2 0923028	6/7 M3 0923029	-	-	-	
49	4	LT 38 N 4 M60-	6/20 M1 0923031	6/10 M3 0923032	6/10 M3 0923033	6/7 M4 0923034	-	-	
100	5	LT 50 N 4 M60-	6/29 M1 0923035	6/20 M2 0923036	6/12 M3 0923037	6/10 M4 0923038	6/7 M5 0923039	-	
139	5	LT 50. 1N 4 M60-	6/29 M1 0923041	6/20 M2 0923042	6/12 M3 0923043	6/10 M4 0923044	6/7 M5 0923045	-	
Cable NSHTÖU-J 4 x 10 mm ²			Ø 25,5 mm				Weight: 0,95 kg/m		
31	3	LT 38 N 4 M60-	6/22 M1 0923046	6/15 M2 0923047	6/10 M3 0923048	6/7 M4 0923049	-	-	
64	4	LT 50 N 4 M60-	6/32 M1 0923051	6/20 M2 0923052	6/10 M4 0923053	6/10 M4 0923054	6/7 M5 0923055	-	
87	4	LT 50. 1N 4 M60-	6/32 M1 0923056	6/20 M2 0923057	6/10 M4 0923058	6/10 M4 0923059	6/7 M5 0923061	-	
150	5	LT 70 N 4 M60-	8/50 M1 0923062	8/28 M2 0923063	8/16 M4 0923064	8/13 M4 0923065	8/12 M5 0923066	8/8 M6 0923067	
168	5	LT 80 N 4 M60-	10/38 M2 0923068	10/26 M3 0923069	10/16 M4 0923071	10/14 M5 0923072	10/11 M6 0923073	10/11 M8 0923074	
Cable NSHTÖU-J 4 x 16 mm ²			Ø 30 mm				Weight: 1,40 kg/m		
23	3	LT 38 N 4 M150-	6/25 M1 0923075	6/15 M3 0923076	6/10 M4 0923077	6/7 M5 0923078	-	-	
50	4	LT 50 N 4 M150-	6/25 M2 0923079	6/20 M3 0923081	6/12 M4 0923082	6/10 M4 0923083	6/7 M8 0923084	-	
80	4	LT 50. 1N 4 M150-	6/29 M2 0923085	6/20 M3 0923086	6/12 M4 0923087	6/10 M5 0923088	6/7 M8 0923089	-	
140	5	LT 70 N 4 M150-	8/41 M2 0923091	8/28 M3 0923092	8/19 M4 0923093	8/13 M5 0923094	8/12 M8 0923095	8/12 M8 0923096	
156	5	LT 80 N 4 M150-	10/44 M2 0923097	10/31 M3 0923098	10/19 M4 0923099	10/16 M5 0923101	10/11 M6 0923102	10/11 M6 0923103	

* LZ = No. of cable layers



REEL SELECTION CHART

Random wrap, shaft gear, horizontal payout

Application

1

Cable NSHTÖU-J 4 x 25 mm ²			Ø 35 mm				Weight: 1,90 kg/m		
active length [m]	LZ*	Reel Type	12 m/min.	20 m/min.	30 m/min.	40 m/min.	50 m/min.	63 m/min.	
30	3	LT 50 N 4 M150-	6/29 M2 0923104	6/20 M3 0923105	6/12 M4 0923106	6/10 M5 0923107	8/8 M8 0923108	-	
47	3	LT 50. 1N 4 M150-	6/29 M2 0923109	6/20 M3 0923111	6/12 M4 0923112	6/10 M5 0923113	8/8 M8 0923114	-	
118	5	LT 70 N 4 M150-	8/41 M2 0923115	8/22 M4 0923116	8/19 M4 0923117	8/13 M8 0923118	8/8 M9 0923119	8/8 M9 0923121	
130	5	LT 80 N 4 M150-	10/41 M3 0923122	10/26 M4 0923123	10/19 M5 0923124	10/16 M8 0923125	10/11 M9 0923126	10/11 M9 0923127	
Cable NSHTÖU-J 4 x 35 mm ²			Ø 39,5 mm				Weight: 2,60 kg/m		
42	3	LT 50. 1N 4 M150-	6/29 M3 0923128	6/17 M4 0923129	6/12 M8 0923131	6/10 M9 0923132	8/7 M9 0923133	-	
80	4	LT 70 N 4 M150-	8/41 M3 0923134	8/25 M4 0923135	8/16 M8 0923136	8/12 M9 0923137	8/12 M9 0923138	8/8 M10 0923139	
118	5	LT 80 N 4 M150-	10/31 M4 0923141	10/31 M4 0923142	10/19 M6 0923143	10/14 M9 0923144	10/11 M10 0923145	10/11 M10 0923146	
Cable NSHTÖU-J 7 x 1,5 mm ²			Ø 19 mm				Weight: 0,43 kg/m		
26	3	LT 28 N 7 K60-	6/15 M1 0923147	6/10 M2 0923148	6/7 M3 0923149	-	-	-	
72	5	LT 38 N 7 K60-	6/22 M1 0923151	6/15 M2 0923152	6/10 M3 0923153	6/7 M4 0923154	-	-	
107	5	LT 50 N 7 K60-	6/25 M1 0923155	6/17 M2 0923156	6/12 M3 0923157	6/10 M4 0923158	6/7 M5 0923159	-	
154	5	LT 50. 1N 7 K60-	6/25 M1 0923161	6/17 M2 0923162	6/12 M3 0923163	6/10 M4 0923164	6/7 M5 0923165	-	
Cable NSHTÖU-J 12 x 1,5 mm ²			Ø 22 mm				Weight: 0,60 kg/m		
14	2	LT 28 N 12 K60-	6/15 M1 0923166	6/10 M2 0923167	6/7 M3 0923168	-	-	-	
49	4	LT 38 N 12 K60-	6/22 M1 0923169	6/15 M2 0923171	6/10 M3 0923172	6/7 M4 0923173	-	-	
92	5	LT 50 N 12 K60-	6/29 M1 0923174	6/20 M2 0923175	6/10 M4 0923176	6/10 M4 0923177	6/7 M5 0923178	-	
139	5	LT 50. 1N 12 K60-	6/29 M1 0923179	6/20 M2 0923181	6/10 M4 0923182	6/10 M4 0923183	6/7 M5 0923184	-	
Cable NSHTÖU-J 24 x 1,5 mm ²			Ø 30,5 mm				Weight: 1,20 kg/m		
24	3	LT 38 N 24 K60-	6/20 M2 0923185	6/15 M3 0923186	6/10 M4 0923187	6/7 M5 0923188	-	-	
43	4	LT 50 N 24 K60-	6/25 M2 0923189	6/20 M3 0923191	6/12 M4 0923192	6/10 M5 0923193	8/8 M8 0923194	-	
74	4	LT 50. 1N 24 K60-	6/29 M2 0923195	6/20 M3 0923196	6/12 M4 0923197	6/10 M5 0923198	8/8 M8 0923199	-	
128	5	LT 70 N 24 K60-	8/41 M2 0923201	8/28 M3 0923202	8/19 M4 0923203	8/13 M5 0923204	8/12 M8 0923205	8/12 M8 0923206	
143	5	LT 80 N 24 K60-	10/44 M2 0923207	10/31 M3 0923208	10/19 M4 0923209	10/16 M5 0923211	10/11 M6 0923212	10/11 M6 0923213	

* LZ = No. of cable layers

REEL SELECTION CHART

Random wrap, shaft gear, horizontal payout

Application **1**



Cable NSHTÖU-J 7 x 2,5 mm ²			Ø 21,5 mm				Weight: 0,56 kg/m		
active length [m]	LZ*	Reel Type	12 m/min.	20 m/min.	30 m/min.	40 m/min.	50 m/min.	63 m/min.	
14	2	LT 28 N 7 K60-	6/15 M1 0923214	6/10 M2 0923215	6/7 M3 0923216	-	-	-	
49	4	LT 38 N 7 K60-	6/22 M1 0923217	6/15 M2 0923218	6/10 M3 0923219	6/7 M4 0923221	-	-	
92	5	LT 50 N 7 K60-	6/29 M1 0923222	6/20 M2 0923223	6/10 M4 0923224	6/10 M4 0923225	6/7 M5 0923226	-	
139	5	LT 50. 1N 7 K60-	6/29 M1 0923227	6/20 M2 0923228	6/10 M4 0923229	6/10 M4 0923231	6/7 M5 0923232	-	
Cable NSHTÖU-J 12 x 2,5 mm ²			Ø 25,5 mm				Weight: 0,85 kg/m		
31	3	LT 38 N 12 K60-	6/22 M1 0923233	6/15 M2 0923234	6/7 M4 0923235	6/7 M4 0923236	-	-	
64	4	LT 50 N 12 K60-	6/32 M1 0923237	6/15 M3 0923238	6/10 M4 0923239	6/10 M4 0923241	6/7 M8 0923242	-	
87	4	LT 50. 1N 12 K60-	6/32 M1 0923243	6/15 M3 0923244	6/10 M4 0923245	6/10 M4 0923246	6/7 M8 0923247	-	
150	5	LT 70 N 12 K60-	8/32 M2 0923248	8/22 M3 0923249	8/16 M4 0923251	8/12 M5 0923252	8/8 M6 0923253	8/8 M6 0923254	
168	5	LT 80 N 12 K60-	10/38 M2 0923255	10/26 M3 0923256	10/16 M4 0923257	10/14 M5 0923258	10/11 M8 0923259	10 /11 M8 0923261	
Cable NSHTÖU-J 18 x 2,5 mm ²			Ø 29,5 mm				Weight: 1,20 kg/m		
27	3	LT 38 N 18 K60-	6/20 M2 0923262	6/15 M3 0923263	6/10 M4 0923264	6/7 M5 0923265	-	-	
58	4	LT 50 N 18 K60-	6/25 M2 0923266	6/20 M3 0923267	6/12 M4 0923268	6/10 M8 0923269	8/8 M8 0923271	-	
81	4	LT 50.1 N18 K60-	6/25 M2 0923272	6/20 M3 0923273	6/12 M4 0923274	6/10 M5 0923275	8/8 M8 0923276	-	
141	5	LT 70 N 18 K60-	8/41 M2 0923277	8/19 M4 0923278	8/13 M5 0923279	8/13 M5 0923281	8/12 M8 0923282	8/8 M9 0923283	
156	5	LT 80 N 18 K60-	10/44 M2 0923284	10/31 M3 0923285	10/19 M4 0923286	10/11 M6 0923287	10/11 M6 0923288	10/11 M6 0923289	
Cable NSHTÖU-J 24 x 2,5 mm ²			Ø 34,5 mm				Weight: 1,65 kg/m		
30	3	LT 50 N 24 K60-	6/29 M2 0923291	6/20 M3 0923292	6/12 M5 0923293	6/10 M8 0923294	8/7 M6 0923295	-	
47	3	LT 50. 1N 24 K60-	6/29 M2 0923296	6/15 M4 0923297	6/12 M5 0923298	6/10 M8 0923299	6/7 M9 0923301	-	
118	5	LT 70 N 24 K60-	8/36 M3 0923302	8/22 M4 0923303	8/16 M5 0923304	8/12 M6 0923305	8/12 M9 0923306	8/7 M10 0923307	
131	5	LT 80 N 24 K60-	10/38 M3 0923308	10/23 M4 0923309	10/19 M5 0923311	10/16 M8 0923312	10/11 M9 0923313	10/11 M9 0923314	
Cable NSHTÖU-J 30 x 2,5 mm ²			Ø 36,5 mm				Weight: 1,90 kg/m		
30	3	LT 50 N 30 K60-	6/32 M2 0923315	6/15 M4 0923316	6/12 M5 0923317	6/10 M8 0923318	6/7 M9 0923319	-	
47	3	LT 50. 1N K60-	6/32 M2 0923321	6/15 M4 0923322	6/12 M5 0923323	6/10 M8 0923324	6/7 M9 0923325	-	
118	5	LT 70 N 30 K60-	8/41 M3 0923326	8/25 M4 0923327	8/19 M5 0923328	8/13 M6 0923329	8/12 M9 0923331	8/7 M10 0923332	
128	5	LT 80 N 30 K60-	10/44 M3 0923333	10/26 M4 0923334	10/16 M6 0923335	10/16 M6 0923336	10/11 M9 0923337	10/11 M9 0923338	

* LZ = No. of cable layers



REEL SELECTION CHART

Random wrap, chain transmission and shaft gear, vertical lift

Application

8

Dimensional data see page 28 for chain transmission			... page 29 for shaft gear transmission		
Cable NSHTÖU-J 4 x 2,5 mm²			Ø 16,5 mm			Weight: 0,33 kg/m		
active length [m]	LZ*	Reel Type	12 m/min.	20 m/min.	30 m/min.	12 m/min.	20 m/min.	30 m/min.
10	1,2	LT 28 S 4 M60-	K/8 M2 0924001	K/8 M2 0924002	K/5 M3 0924003	6/12 M1 0924004	6/10 M2 0924005	6/7 M3 0924006
20	1,6	LT 38 S 4 M60-	K/9 M3 0924007	K/9 M3 0924008	K/6 M4 0924009	6/20 M1 0924011	6/11 M3 0924012	6/7 M4 0924013
Cable NSHTÖU-J 4 x 4 mm²			Ø 19,5 mm			Weight: 0,47 kg/m		
10	1,4	LT 28 S 4 M60-	K/9 M2 0924014	K/9 M2 0924015	K/6 M3 0924016	6/15 M1 0924017	6/10 M2 0924018	6/7 M3 0924019
20	1,8	LT 38 S 4 M60-	K/7 M4 0924021	K/7 M4 0924022	K/7 M4 0924023	6/17 M2 0924024	6/12 M3 0924025	6/10 M4 0924026
30	2,5	LT 38 S 4 M60-	K/9 M4 0924027	K/9 M4 0924028	K/7 M5 0924029	6/20 M2 0924031	6/10 M4 0924032	6/7 M5 0924033
Cable NSHTÖU-J 4 x 6 mm²			Ø 21 mm			Weight: 0,60 kg/m		
10	1,6	LT 28 S 4 M60-	K/8 M3 0924034	K/8 M3 0924035	K/5 M4 0924036	6/12 M2 0924037	6/10 M3 0924038	6/7 M4 0924039
20	1,9	LT 38 S 4 M60-	K/8 M4 0924041	K/8 M4 0924042	K/8 M4 0924043	6/20 M2 0924044	6/10 M4 0924045	6/10 M4 0924046
30	2,7	LT 38 S 4 M60-	KG/17 M3 0924047	K/8 M5 0924048	K/8 M5 0924049	6/17 M3 0924051	6/12 M4 0924052	6/10 M5 0924053
Cable NSHTÖU-J 4 x 10 mm²			Ø 25,5 mm			Weight: 0,95 kg/m		
10	1,3	LT 38 S 4 M60-	K/8 M4 0924054	K/8 M4 0924055	K/8 M4 0924056	6/20 M2 0924057	6/10 M4 0924058	6/7 M5 0924059
20	2,1	LT 38 S 4 M60-	KG/19 M3 0924061	K/9 M5 0924062	K/8 M8 0924063	6/20 M3 0924064	6/12 M4 0924065	6/10 M8 0924066
30	2,9	LT 38 S 4 M60-	KG/16 M4 0924067	K/8 M6 0924068	K/8 M6 0924069	6/17 M4 0924071	6/12 M8 0924072	6/7 M9 0924073
Cable NSHTÖU-J 4 x 16 mm²			Ø 30 mm			Weight: 1,40 kg/m		
10	1,6	LT 38 S 4 M150-	KG/17 M3 0924074	K/8 M5 0924075	K/8 M5 0924076	6/20 M3 0924077	6/12 M4 0924078	6/10 M8 0924079
20	2,6	LT 38 S 4 M150-	KG/16 M4 0924081	K/9 M6 0924082	K/9 M6 0924083	6/17 M4 0924084	6/12 M8 0924085	6/7 M9 0924086
30	2,7	LT 50 S 4 M150-	KG/29 M4 0924087	K/8 M10 0924088	K/8 M10 0924089	6/29 M4 0924091	8/16 M6 0924092	8/12 M10 0924093
Cable NSHTÖU-J 4 x 25 mm²			Ø 35 mm			Weight: 1,90 kg/m		
10	1,3	LT 50 S 4 M150-	KG/29 M3 0924094	KG/18 M4 0924095	K/8 M9 0924096	6/29 M3 0924097	6/15 M5 0924098	6/10 M9 0924099
20	2,2	LT 50 S 4 M150-	KG/29 M4 0924101	K/8 M10 0924102	K/8 M10 0924103	6/29 M4 0924104	8/16 M6 0924105	8/12 M10 0924106

* LZ = No. of cable layers

REEL SELECTION CHART

Random wrap, chain transmission and shaft gear, vertical lift

Application

8



Dimensinal data see page 28 for chain transmission			... page 29 for shaft gear transmission		
Cable NSHTÖU-J 12 x 1,5 mm²			Ø 22 mm			Weight: 0,60 kg/m		
active length [m]	LZ*	Reel Type	12 m/min.	20 m/min.	30 m/min.	12 m/min.	20 m/min.	30 m/min.
10	1,5	LT 28 S 12 K60-	K/8 M3 0924107	K/8 M3 0924108	K/5 M4 0924109	6/12 M2 0924111	6/10 M3 0924112	6/7 M4 0924113
20	1,9	LT 38 S 12 K60-	K/8 M4 0924114	K/8 M4 0924115	K/8 M4 0924116	6/20 M2 0924117	6/10 M4 0924118	6/10 M4 0924119
30	2,7	LT 38 S 12 K60-	KG/17 M3 0924121	K/8 M5 0924122	K/8 M5 0924123	6/20 M3 0924124	6/12 M4 0924125	6/10 M5 0924126
Cable NSHTÖU-J 24 x 1,5 mm²			Ø 30,5 mm			Weight: 1,20 kg/m		
10	1,6	LT 38 S 24 K60-	KG/17 M3 0924127	K/8 M5 0924128	K/8 M5 0924129	6/17 M3 0924131	6/12 M4 0924132	6/7 M8 0924133
20	2,6	LT 38 S 24 K60-	KG/16 M4 0924134	K/8 M6 0924135	K/8 M6 0924136	6/17 M4 0924137	6/12 M5 0924138	6/7 M9 0924139
30	2,7	LT 50 S 24 K60-	KG/26 M4 0924141	K/8 M10 0924142	K/8 M10 0924143	6/25 M4 0924144	6/17 M8 0924145	8/8 M10 0924146
Cable NSHTÖU-J 7 x 2,5 mm²			Ø 21,5 mm			Weight: 0,56 kg/m		
10	1,5	LT 28 S 7 K60-	K/7 M3 0924147	K/7 M3 0924148	K/7 M3 0924149	6/12 M2 0924151	6/10 M3 0924152	6/7 M4 0924153
20	1,9	LT 38 S 7 K60-	K/8 M4 0924154	K/8 M4 0924155	K/8 M4 0924156	6/20 M2 0924157	6/10 M4 0924158	6/10 M4 0924159
30	2,7	LT 38 S 7 K60-	KG/24 M2 0924161	K/8 M5 0924162	K/8 M5 0924163	6/17 M3 0924164	6/12 M4 0924165	6/10 M5 0924166
Cable NSHTÖU-J 12 x 2,5 mm²			Ø 25,5 mm			Weight: 0,85 kg/m		
10	1,3	LT 38 S 12 K60-	K/8 M4 0924167	K/8 M4 0924168	K/8 M4 0924169	6/20 M2 0924171	6/10 M4 0924172	6/7 M5 0924173
20	2,1	LT 38 S 12 K60-	KG/18 M3 0924174	K/9 M5 0924175	K/9 M5 0924176	6/20 M3 0924177	6/12 M4 0924178	6/10 M8 0924179
30	2,9	LT 38 S 12 K60-	KG/23 M3 0924181	K/9 M8 0924182	K/8 M6 0924183	6/15 M4 0924184	6/12 M5 0924185	8/8 M6 0924186
Cable NSHTÖU-J 18 x 2,5 mm²			Ø 29,5 mm			Weight: 1,20 kg/m		
10	1,4	LT 38 S 18 K60-	KG/24 M2 0924187	K/8 M5 0924188	K/8 M5 0924189	6/22 M2 0924191	6/12 M4 0924192	6/7 M8 0924193
20	2,3	LT 38 S 18 K60-	KG/23 M3 0924194	K/9 M8 0924195	K/8 M6 0924196	6/22 M3 0924197	6/12 M5 0924198	6/7 M9 0924199
30	2,4	LT 50 S 18 K60-	KG/26 M4 0924201	K/8 M10 0924202	K/8 M10 0924203	6/25 M4 0924204	6/17 M8 0924205	6/12 M9 0924206
Cable NSHTÖU-J 24 x 2,5 mm²			Ø 34,5 mm			Weight: 1,65 kg/m		
10	1,3	LT 50 S 24 K60-	KG/27 M3 0924207	KG/18 M4 0924208	K/9 M6 0924209	6/29 M3 0924211	6/17 M4 0924212	6/12 M8 0924213
20	2,2	LT 50 S 24 K60-	KG/26 M4 0924214	K/8 M10 0924215	K/8 M10 0924216	6/25 M4 0924217	6/17 M8 0924218	6/12 M9 0924219
Cable NSHTÖU-J 30 x 2,5 mm²			Ø 36,5 mm			Weight: 1,90 kg/m		
10	1,3	LT 50 S 30 K60-	KG/31 M3 0924221	KG/16 M5 0924222	K/8 M9 0924223	6/32 M3 0924224	6/17 M5 0924225	6/10 M9 0924226
20	2,2	LT 50. 1S 30 K60-	KG/29 M4 0924227	K/8 M10 0924228	K/8 M10 0924229	6/29 M4 0924231	6/12 M9 0924232	6/12 M9 0924233

* LZ = No. of cable layers



REEL DIMENSIONAL DATA for selection charts pages 19-21 and 26-27

Random wrap, chain transmission

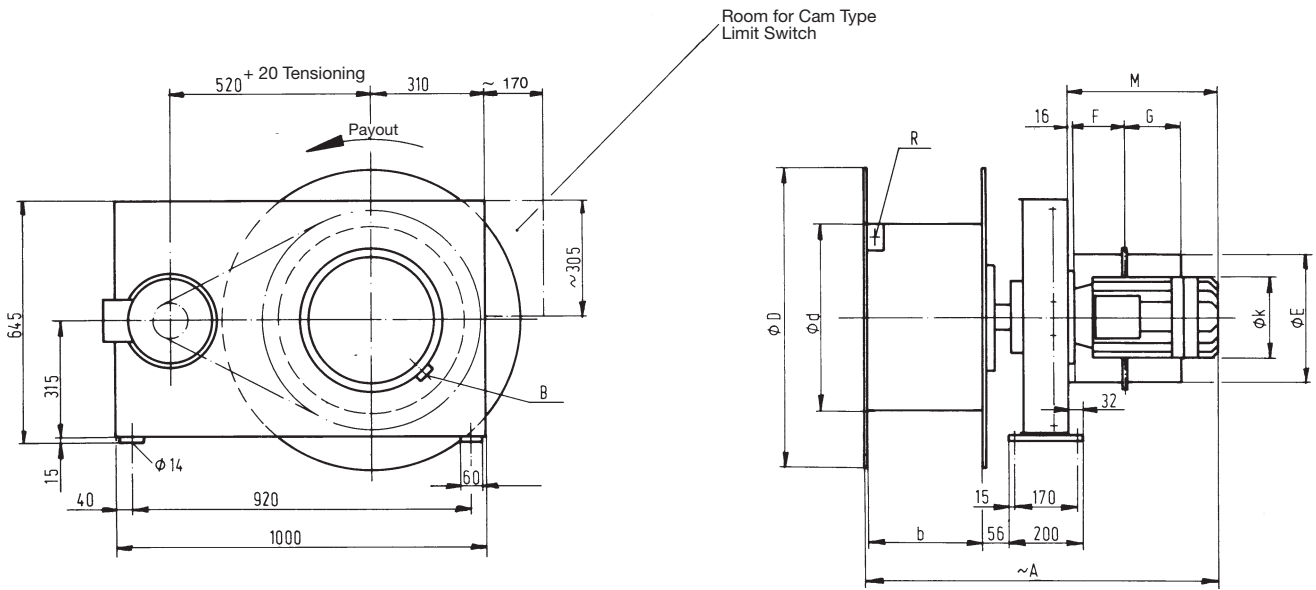

B = Cable entrance to brushes
R = Cable entrance to rings

Application 1

horizontal payout - installation height max. 1.5 m

Type	A	b	ϕd	ϕD	ϕk	M	~ kg
LT 28 N...-K	910	200	280	450	246	482	275
LT 38 N...-K	980	220	380	650	274	530	330
...-KG	970				158	520	260
LT 50 N...-K	1140	250	500	800	274	660	380
...-KG	1170				220	690	300
LT 50. 1N...-K	1240	350	500	900	274	660	400
...-KG	1270				220	690	310
LT 70 N...-K	1240	350	700	1200	274	660	470
...-KG	1270				220	690	390

Dimensional Data of collector assembly hoods

p. dwgs. page 28 and 29.

SRK-Type	E	F	G
4 M 60	$\phi 340$	153	153
4 M150			
7 K 60			
12 K 60			353
18 K 60			
24 K 60			
30 K 60	553		

Application 8

vertical lift

Type	A	b	ϕd	ϕD	ϕk	M	~ kg
LT 28 S...-K	832	200	280	450	220	405	260
LT 38 S...-K	960	220	380	650	224	513	300
...-KG	1140				220	690	280
LT 50 S...-K	1140	250	500	800	274	660	380
...-KG	1170				220	690	300
LT 50. 1S...-K	1240	350	500	900	274	660	400
...-KG	1270				220	690	310

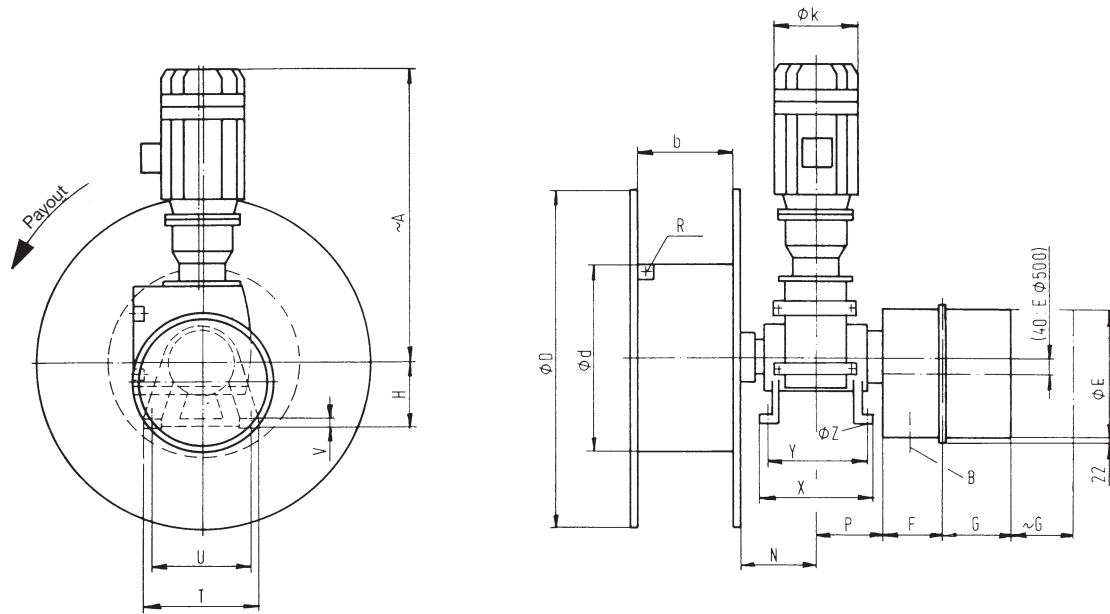

B = Cable entrance to brushes
 R = Cable entrance to rings

Application 1

horizontal payout - installation high max. 1.5 m

Type	A	b	Ø d	Ø D	H	Ø k	N	P	T	U	V	X	Y	Ø Z	≈ kg
LT 28 N...- 6	705	200	280	450	140	196	229	161	250	210	20	250	220	13	190
LT 38 N...- 6	860	220	380	650	140	246	229	161	250	210	20	250	220	13	240
LT 50 N...- 6	945	250	500	800	140	250	229	161	250	210	20	250	220	13	270
...- 8					175	255	187	300	240	25	300	260	17	320	
LT 50.1N...- 6	945	350	500	900	140	250	229	161	250	210	20	250	220	13	290
...- 8					175	255	187	300	240	25	300	260	17	350	
LT 70 N...- 8	1055	350	700	1200	175	274	255	187	300	240	25	300	260	17	460
LT 80 N...-10	1080	350	800	1400	210	274	310	296	380	310	30	355	300	22	550

Application 8

vertical lift

Type	A	b	Ø d	Ø D	H	Ø k	N	P	T	U	V	X	Y	Ø Z	≈ kg
LT 28 S...- 6	780	200	280	450	140	220	229	161	250	210	20	250	220	13	200
LT 38 S...- 6	945	220	380	650	140	250	229	161	250	210	20	250	220	13	260
LT 50 S...- 6	945	250	500	800	140	250	229	161	250	210	20	250	220	13	270
...- 8					1055	175	274	255	187	300	240	25	300	260	17
LT 50.1S...- 6	780	350	500	900	140	220	229	161	250	210	20	250	220	13	250
...- 8					1055	175	274	255	187	300	240	25	300	260	17



For torque motor series

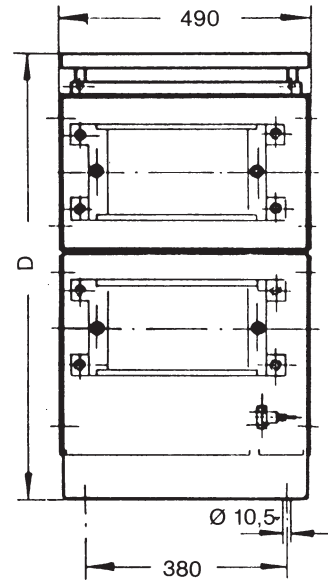
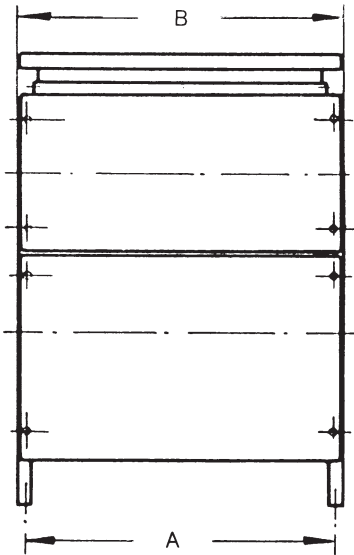

Standard Resistor Type FT, IP 13*

for size	A	B	D	~ kg	Cat.-No.
M 7	570	595	520	35	0926001
M 8	370	395		25	0926002
M 9					0926003
M 10	0926004				
M 11	570	595	520	35	0926005
M 12	0926006				
M 13	770	795	770	50	0926007
M 14	0926008				

Step Resistor Type FS, IP 23

for size	A	B	D	~ kg	Cat.-No.
R 7	770	795	520	50	0926016
R 8					0926017
R 9	570	595		35	0926018
R 10					0926019
R 11	770	795	770	50	0926021
R 12	0926022				
R 13	970	995	1100	85	0926023
R 14				100	0926024

Resistors to be installed as shown. Cooling is important. Dissipating air temperature can reach 200 °C. Connecting cable between reel drive motor and resistor should not exceed 10 m of length; otherwise check wire size.

For motors with frequency converter

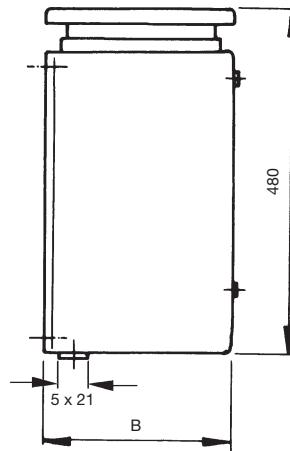
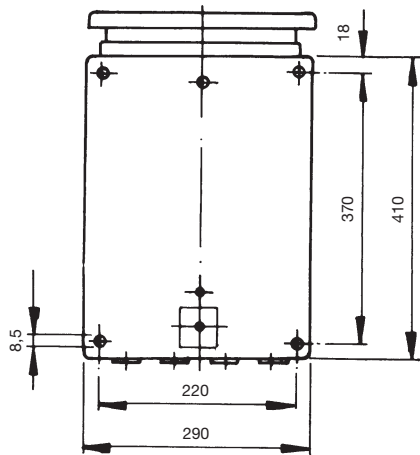

FSL...
wall mounting

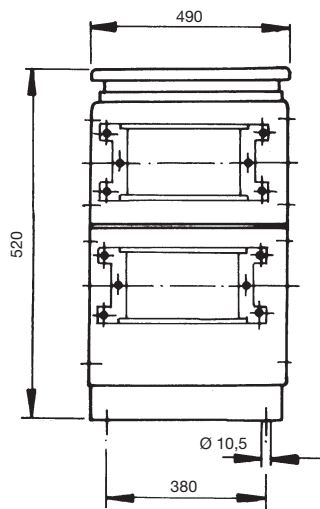
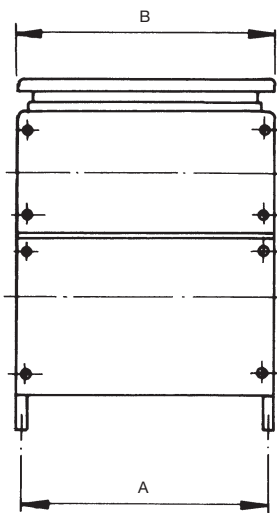

FS...
foot mounting

Protection code: IP 23

for size	Resistor Type	A mm	B mm	kg	Cat.-No.
B	FSL 19	-	200	15	0926588
C					0926589
D					0926590
E					0926591
F					0926592
G					0926593
H	FSL 20		335	25	0926594
J	FS 311	370	395	35	0926595
K	FS 312	570	595		0926596
L					0926597
M	FS 313	770	795	50	0926598



WIRING DIAGRAMS

for Motor powered cable reels with frequency converter drive

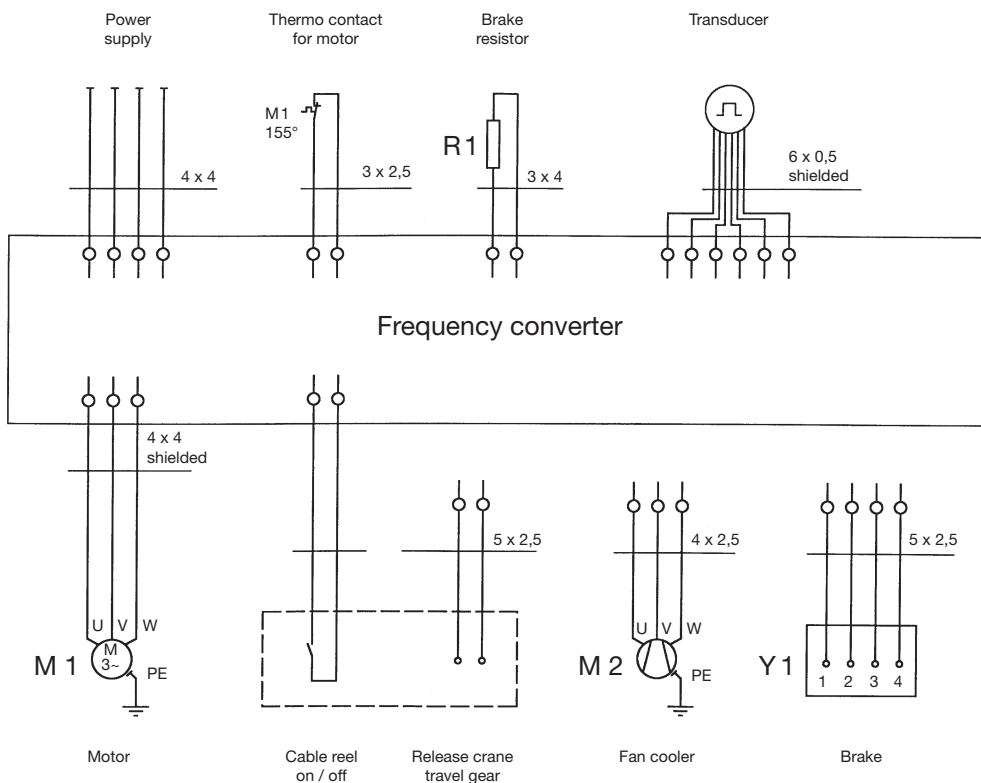
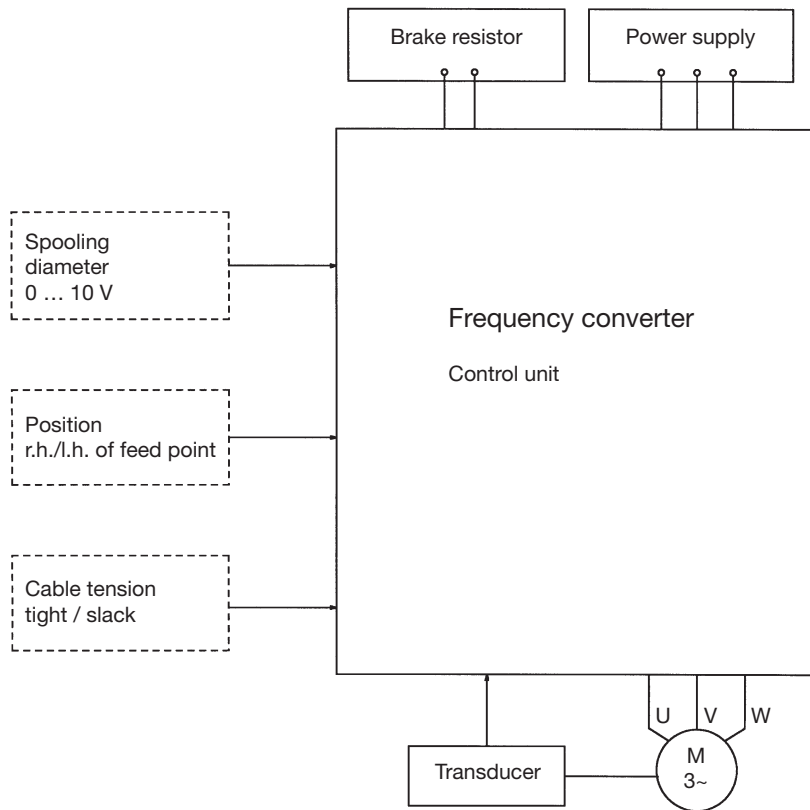

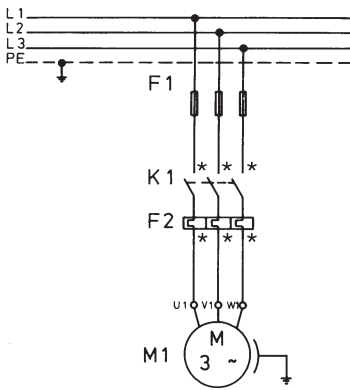

Squirrel cage torque motor

F1 Fuse main supply
 F2 Overload relay
 M1 Stall torque motor

K1 Start Contactor
 – at 100 % DF: activated by control voltage (not travel motor connected)
 – at intermittent service: activated via travel motor (time-lag min. 15 s)

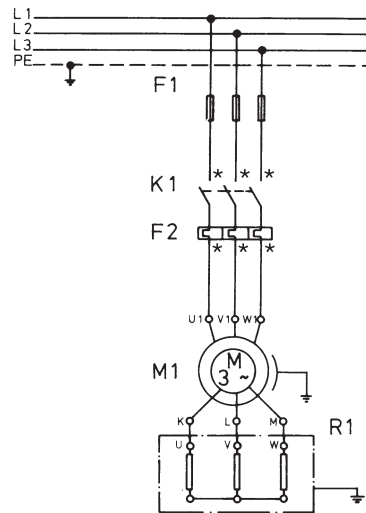

Slipping type torque motor with Standard Resistor

F1 Fuse main supply
 F2 Overload relay
 M1 Stall torque motor
 R1 Standard Resistor

K1 Start Contactor
 – at 100 % DF: activated by control voltage (not travel motor connected)
 – at intermittent service: activated via travel motor (time-lag min. 15 s)

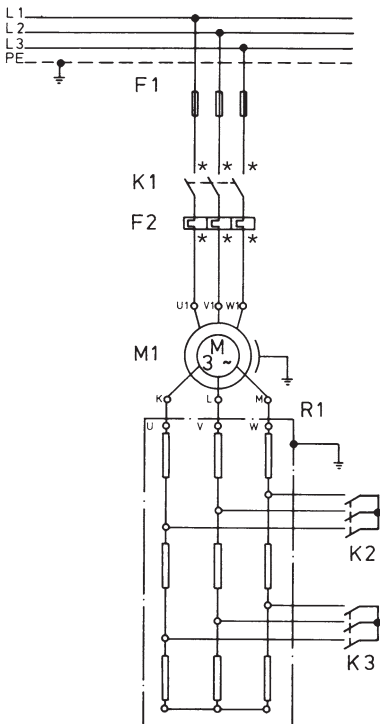

Slipping type torque motor with Step Resistor for torque setting

F1 Fuse main supply
 F2 Overload relay
 M1 Stall torque motor
 R1 Standard Resistor

K1 Start Contactor
 – at 100 % DF: activated by control voltage (not travel motor connected)
 – at intermittent service: activated via travel motor (time-lag min. 15 s)

Torque Regulation:

K2, K3 Torque moment selector with factory preset switch points

Activating: via cam type limit switch attached to the cable reel



VAHLE MOTOR POWERED CABLE REELS

Magnet Coupling Series

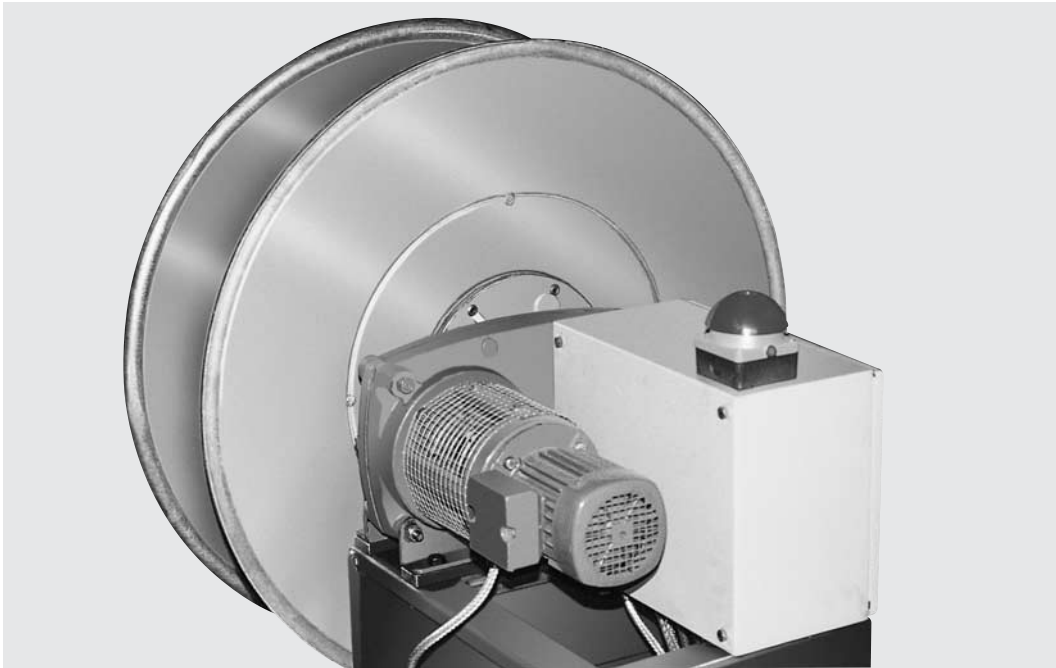

Type LTM 50.1 N 24 K 60-95/42 M A

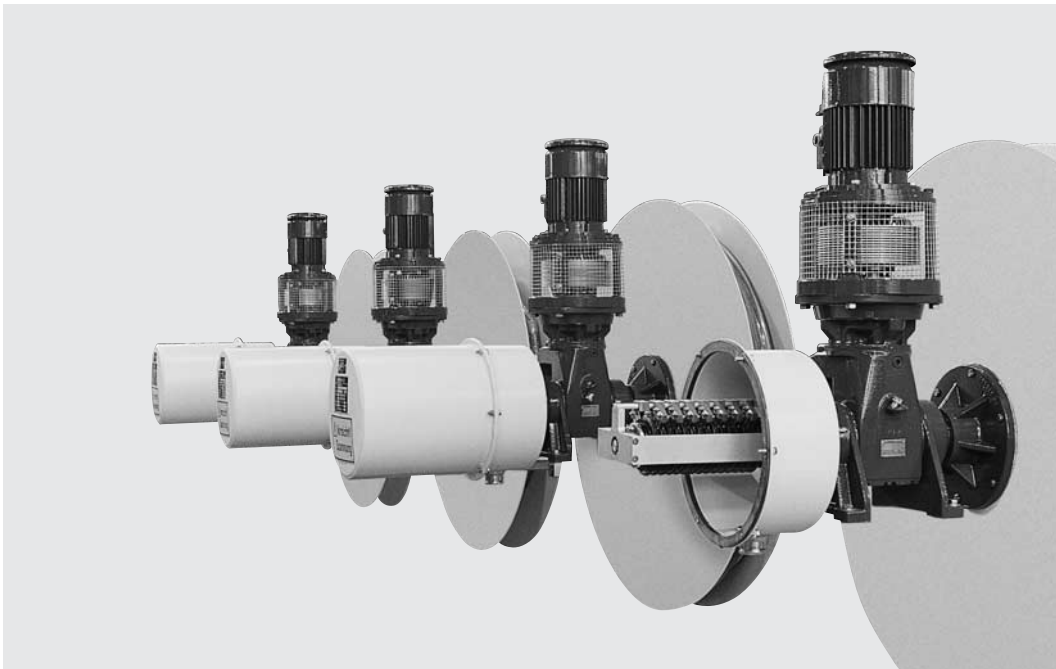

Type LTM 4/11 N 30 P 25-6/29 M 6 D



These electric motor driven reels use permanent magnet couplings for the required torque effect.

Two coupling sizes are available:

- No. 1.8 for a constant torque moment
- No. 7 for an adjustable torque moment (by changing the airgap).

The adequate starting torque of the standard AC Motor in any cycling or voltage is higher than the magnet coupling torque.

While the primary side works per the motor rotation (in the reeling up direction) the secondary coupling side rotates per the travel speed of the moving equipment.

- n = 0 standstill
- n = - retrieve
- n = + payout

keeping always a minimum torque moment set by the factory in accordance to the speed envisaged.

A back-stop device on the motor holds the cable in place when power is shut off.

Up to the certain air gap (torque moment) the coupling sizes 1.8 and 7 can operate at 100 % DF e. g. the electric motor running continuously under power, as long as the moving equipment is in operation.

A drive-connected, intermittent service requires a built in timer maintaining cable pickup as the moving equipment decelerates after shutdown.

A few reel models, using coupling No. 7 require a payout sensor detecting the rotation of the reel ensuring that the reel motor is energized during cable recovery and de-energized during cable payout. This results in energy savings and extended unit life. See reel selection charts (*) and wiring diagram.



LTM MODEL EXPLANATION

Reel type definition

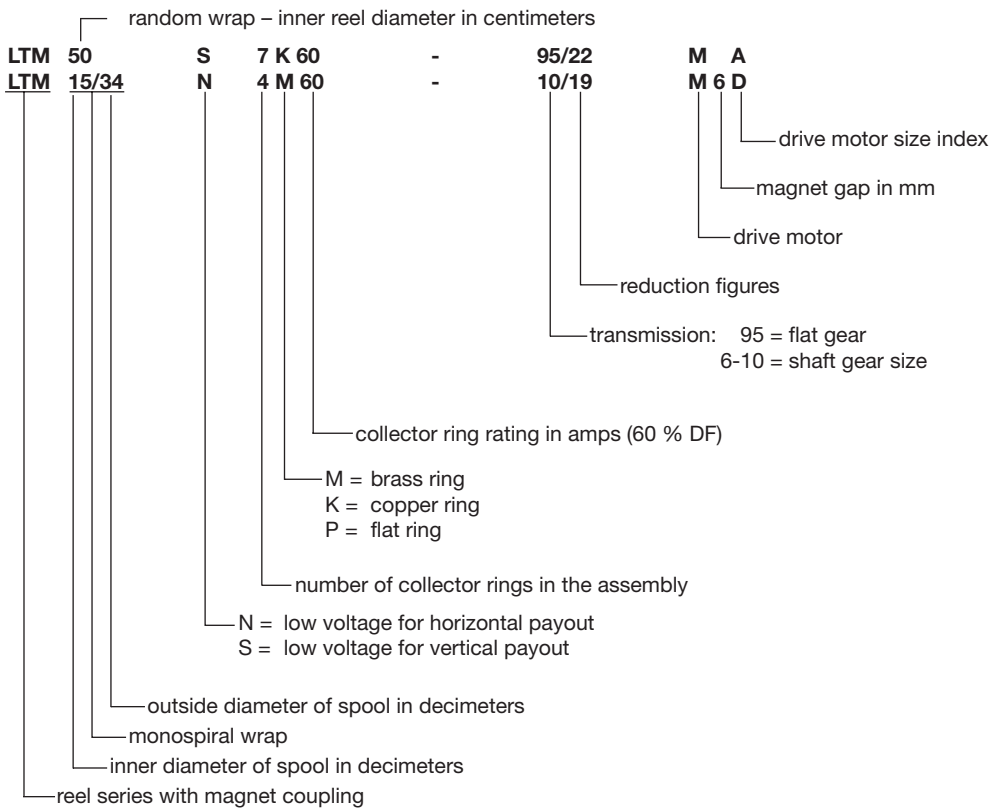

All Models are less cable

Reel Selection – Example

Job function requiring a reel for:

Active cable length	: 30 m
No. of conductors x wire size	: 4 x 6 mm ²
Cable diameter	: 21 mm
Cable weight	: 0,6 kg/m
Operating speed	: 40m/min
Application	: case 1
Spool type	: monospiral

The selection per chart on page 37:

Type : **LTM 6/12 N 4 M 60-95/51 MA**
 Cat.-No. : **0924429**

REEL SELECTION CHART

Monospiral wrap, shaft gear, horizontal payout

Applications

1 2



Cable NSHTÖU-J 4 x 6 mm ²		Ø 21 mm		Weight: 0,60 kg/m	
active length [m]	Type	20 m/min	40 m/min	60 m/min	80 m/min
30	LTM 6/12 N 4 M60-	95/51 MA 0924429	95/51 MA 0924429	6/20 M 6 D 0924432	6/20 M 6 D 0924432
57	LTM 6/15 N 4 M60-	6/25 M 6 D 0924433	6/25 M 6 D 0924433	6/25 M 6 D 0924433	6/25 M 6 D 0924433
79	LTM 8/18 N 4 M60-	6/32 M 6 D 0924434	6/32 M 6 D 0924434	6/32 M 6 D 0924434	6/32 M 6 D 0924434
126	LTM 8/21 N 4 M60-	6/36 M 6 D 0924435	6/36 M 6 D 0924435	6/36 M 6 D 0924435	6/25 M 4 E 0924436
Cable NSHTÖU-J 4 x 10 mm ²		Ø 25,5 mm		Weight: 0,95 kg/m	
25	LTM 6/12 N 4 M60-	6/22 M 6 D 0924437	6/22 M 6 D 0924437	6/22 M 6 D 0924437	6/22 M 6 D 0924437
48	LTM 6/15 N 4 M60-	6/29 M 6 D 0924438	6/29 M 6 D 0924438	6/29 M 6 D 0924438	6/20 M 4 E 0924439
68	LTM 8/18 N 4 M60-	6/36 M 6 D 0924441	6/36 M 6 D 0924441	6/36 M 6 D 0924441	6/25 M 4 E 0924442
104	LTM 8/21 N 4 M60-	6/45 M 6 D 0924443	6/45 M 6 D 0924443	6/45 M 6 D 0924443	6/29 M 4 E 0924444
133	LTM 12/25 N 4 M60-	8/57 M 6 D 0924445	8/57 M 6 D 0924445	8/57 M 6 D 0924445	8/36 M 4 E 0924446
Cable NSHTÖU-J 4 x 16 mm ²		Ø 30 mm		Weight: 1,40 kg/m	
19	LTM 6/12 N 4 M150-	6/29 M 6 D 0924447	6/29 M 6 D 0924447	6/29 M 6 D 0924447	6/20 M 4 E 0924448
38	LTM 6/15 N 4 M150-	6/36 M 6 D 0924449	6/36 M 6 D 0924449	6/36 M 6 D 0924449	6/25 M 4 E 0924451
56	LTM 8/18 N 4 M150-	6/45 M 6 D 0924452	6/45 M 6 D 0924452	6/45 M 6 D 0924452	6/32 M 4 E 0924453
85	LTM 8/21 N 4 M150-	6/60 M 6 D 0924454	6/60 M 6 D 0924454	6/36 M 4 E 0924455	6/36 M 4 E 0924455
109	LTM 12/25 N 4 M150-	8/67 M 6 D 0924456	8/67 M 6 D 0924456	8/50 M 4 E 0924457	8/50 M 4 E 0924457
153	LTM 15/30 N 4 M150-	8/67 M 4 E 0924458	8/67 M 4 E 0924458	8/67 M 4 E 0924458	-
Cable NSHTÖU-J 4 x 25 mm ²		Ø 35 mm		Weight: 1,90 kg/m	
16	LTM 6/12 N 4 M150-	6/32 M 6 D 0924461	6/32 M 6 D 0924461	6/32 M 6 D 0924461	6/22 M 4 E 0924462
32	LTM 6/15 N 4 M150-	6/45 M 6 D 0924463	6/45 M 6 D 0924463	6/29 M 4 E 0924464	6/29 M 4 E 0924464
48	LTM 8/18 N 4 M150-	6/51 M 6 D 0924465	6/51 M 6 D 0924465	6/36 M 4 E 0924466	6/36 M 4 E 0924466
72	LTM 8/21 N 4 M150-	6/45 M 4 E 0924467	6/45 M 4 E 0924467	6/45 M 4 E 0924467	-
92	LTM 12/25 N 4 M150-	8/57 M 4 E 0924469	8/57 M 4 E 0924469	8/57 M 4 E 0924469	-
133	LTM 15/30 N 4 M150-	8/76 M 4 E 0924472	8/76 M 4 E 0924472	8/76 M 4 E 0924472	-



REEL SELECTION CHART

Monospiral wrap, shaft gear, horizontal payout

Applications

1 2

Cable NSHTÖU-J 4 x 25 mm ²		Ø 35 mm		Weight: 1,90 kg/m	
active length [m]	Type	20 m/min	40 m/min	60 m/min	80 m/min
150	LTM 12/30 N 4 M150-	8/76 M 4 E 0924473	8/76 M 4 E 0924473	–	–
182	LTM 15/34 N 4 M150-	10/105 M 4 E 0924475	10/105 M 4 E 0924475	–	–
Cable NSHTÖU-J 4 x 35 mm ²		Ø 39,5 mm		Weight: 2,60 kg/m	
13	LTM 6/12 N 4 M150-	6/29 M 4 E 0924477	6/29 M 4 E 0924477	6/29 M 4 E 0924477	6/29 M 4 E 0924477
29	LTM 6/15 N 4 M150-	6/36 M 4 E 0924478	6/36 M 4 E 0924478	6/36 M 4 E 0924478	–
40	LTM 8/18 N 4 M150-	6/45 M 4 E 0924481	6/45 M 4 E 0924481	6/45 M 4 E 0924481	–
63	LTM 8/21 N 4 M150-	6/51 M 4 E 0924483	6/51 M 4 E 0924483	–	–
80	LTM 12/25 N 4 M150-	8/57 M 3 E 0924485	–	–	–
111	LTM 15/30 N 4 M150-	10/73 M 3 E 0924487	–	–	–
130	LTM 12/30 N 4 M150-	10/73 M 3 E 0924489	–	–	–
159	LTM 15/34 N 4 M150-	10/94 M 3 E 0924492	–	–	–
Cable NSHTÖU-J 4 x 50 mm ²		Ø 46,5 mm		Weight: 3,60 kg/m	
48	LTM 8/21 N 4 M300-	8/67 M 4 E 0924494	8/67 M 4 E 0924494	–	–
62	LTM 12/25 N 4 M300-	8/85 M 4 E 0924496	8/85 M 4 E 0924496	–	–
90	LTM 15/30 N 4 M300-	10/94 M 3 E 0924498	–	–	–
111	LTM 12/30 N 4 M300-	10/94 M 3 E 0924501	–	–	–
Cable NSHTÖU-J 4 x 70 mm ²		Ø 51 mm		Weight: 4,60 kg/m	
57	LTM 12/25 N 4 M300-	10/84 M 3 E 0924503	–	–	–
83	LTM 15/30 N 4 M300-	10/105 M 3 E 0924505	–	–	–
Cable NSHTÖU-J 24 x 1,5 mm ²		Ø 30,5 mm		Weight: 1,20 kg/m	
19	LTM 6/12 N 24 K60-	6/25 M 6 D 0924507	6/25 M 6 D 0924507	6/25 M 6 D 0924507	6/25 M 6 D 0924507
38	LTM 6/15 N 24 K60-	6/36 M 6 D 0924508	6/36 M 6 D 0924508	6/36 M 6 D 0924508	6/25 M 4 E 0924509
56	LTM 8/18 N 24 K60-	6/45 M 6 D 0924511	6/45 M 6 D 0924511	6/45 M 6 D 0924511	6/29 M 4 E 0924512

REEL SELECTION CHART

Monospiral wrap, shaft gear, horizontal payout

Applications

1 2



Cable NSHTÖU-J 24 x 1,5 mm ²		Ø 30,5 mm		Weight: 1,20 kg/m	
active length [m]	Type	20 m/min	40 m/min	60 m/min	80 m/min
86	LTM 8/21 N 24 K60-	6/51 M 6 D 0924513	6/51 M 6 D 0924513	6/36 M 4 E 0924514	6/36 M 4 E 0924514
110	LTM 12/25 N 24 K60-	8/67 M 6 D 0924515	8/67 M 6 D 0924515	8/67 M 6 D 0924515	8/41 M 4 E 0924516
154	LTM 15/30 N 24 K60-	8/85 M 6 D 0924517	8/85 M 6 D 0924517	8/57 M 4 E 0924518	8/57 M 4 E 0924518
Cable NSHTÖU-J 12 x 2,5 mm ²		Ø 25,5 mm		Weight: 0,85 kg/m	
25	LTM 6/12 N 12 K60-	6/22 M 6 D 0924519	6/22 M 6 D 0924519	6/22 M 6 D 0924519	6/22 M 6 D 0924519
48	LTM 6/15 N 12 K60-	6/29 M 6 D 0924521	6/29 M 6 D 0924521	6/29 M 6 D 0924521	6/20 M 4 E 0924522
68	LTM 8/18 N 12 K60-	6/36 M 6 D 0924523	6/36 M 6 D 0924523	6/36 M 6 D 0924523	6/25 M 4 E 0924524
104	LTM 8/21 N 12 K60-	6/45 M 6 D 0924525	6/45 M 6 D 0924525	6/45 M 6 D 0924525	6/29 M 4 E 0924526
133	LTM 12/25 N 12 K60-	8/57 M 6 D 0924527	8/57 M 6 D 0924527	8/57 M 6 D 0924527	8/36 M 4 E 0924528
181	LTM 15/30 N 12 K 60-	8/76 M 6 D 0924529	8/76 M 6 D 0924529	8/76 M 6 D 0924529	8/50 M 4 E 0924531
Cable NSHTÖU-J 18 x 2,5 mm ²		Ø 29,5 mm		Weight: 1,20 kg/m	
19	LTM 6/12 N 18 K60-	6/25 M 6 D 0924532	6/25 M 6 D 0924532	6/25 M 6 D 0924532	6/25 M 6 D 0924532
38	LTM 6/15 N 18 K60-	6/36 M 6 D 0924533	6/36 M 6 D 0924533	6/36 M 6 D 0924533	6/22 M 4 E 0924534
56	LTM 8/18 N 18 K60-	6/45 M 6 D 0924535	6/45 M 6 D 0924535	6/45 M 6 D 0924535	6/29 M 4 E 0924536
85	LTM 8/21 N 18 K60-	6/51 M 6 D 0924537	6/51 M 6 D 0924537	6/36 M 4 E 0924538	6/36 M 4 E 0924538
108	LTM 12/25 N 18 K60-	8/67 M 6 D 0924539	8/67 M 6 D 0924539	8/67 M 6 D 0924539	8/41 M 4 E 0924541
153	LTM 15/30 N 18 K60-	8/85 M 6 D 0924542	8/85 M 6 D 0924542	8/57 M 4 E 0924543	8/57 M 4 E 0924543
176	LTM 12/30 N 18 K60-	8/67 M 4 E 0924544	8/67 M 4 E 0924544	8/67 M 4 E 0924544	-
220	LTM 15/34 N 18 K60-	10/84 M 4 E 0924546	10/84 M 4 E 0924546	10/84 M 4 E 0924546	-
Cable NSHTÖU-J 24 x 2,5 mm ²		Ø 34,5 mm		Weight: 1,65 kg/m	
16	LTM 6/12 N 24 K60-	6/32 M 6 D 0924548	6/32 M 6 D 0924548	6/32 M 6 D 0924548	6/22 M 4 E 0924549
32	LTM 6/15 N 24 K60-	6/36 M 6 D 0924551	6/36 M 6 D 0924551	6/36 M 6 D 0924551	6/25 M 4 E 0924552
48	LTM 8/18 N 24 K60-	6/51 M 6 D 0924553	6/51 M 6 D 0924553	6/32 M 4 E 0924554	6/32 M 4 E 0924554
71	LTM 8/21 N 24 K60-	6/60 M 6 D 0924555	6/60 M 6 D 0924555	6/45 M 4 E 0924556	-



REEL SELECTION CHART

Monospiral wrap, shaft gear, horizontal payout

Applications

1 2

Cable NSHTÖU-J 24 x 2,5 mm ²		Ø 34,5 mm		Weight: 1,65 kg/m	
active length [m]	Type	20 m/min	40 m/min	60 m/min	80 m/min
91	LTM 12/25 N 24 K60-	8/76 M 6 D 0924558	8/76 M 6 D 0924558	8/50 M 4 E 0924559	8/50 M 4 E 0924559
133	LTM 15/30 N 24 K60-	8/67 M 4 E 0924561	8/67 M 4 E 0924561	8/67 M 4 E 0924561	-
149	LTM 12/30 N 24 K60-	8/67 M 4 E 0924563	8/67 M 4 E 0924563	8/67 M 4 E 0924563	-
191	LTM 15/34 N 24 K60-	10/94 M 4 E 0924564	10/94 M 4 E 0924564	-	-
Cable NSHTÖU-J 30 x 2,5 mm ²		Ø 36,5 mm		Weight: 1,90 kg/m	
13	LTM 6/12 N 30 K60-	6/32 M 6 D 0924566	6/32 M 6 D 0924566	6/32 M 6 D 0924566	6/22 M 4 E 0924567
32	LTM 6/15 N 30 K60-	6/45 M 6 D 0924568	6/45 M 6 D 0924568	6/29 M 4 E 0924569	-
44	LTM 8/18 N 30 K60-	6/51 M 6 D 0924572	6/51 M 6 D 0924572	6/36 M 4 E 0924573	6/36 M 4 E 0924573
67	LTM 8/21 N 30 K60-	6/67 M 6 D 0924574	6/67 M 6 D 0924574	6/45 M 4 E 0924575	-
86	LTM 12/25 N 30 K60-	8/85 M 6 D 0924577	8/85 M 6 D 0924577	8/57 M 4 E 0924578	-
126	LTM 15/30 N 30 K60-	8/76 M 4 E 0924581	8/76 M 4 E 0924581	8/76 M 4 E 0924581	-
143	LTM 12/30 N 30 K60-	8/76 M 4 E 0924583	8/76 M 4 E 0924583	-	-
174	LTM 15/34 N 30 K60-	10/94 M 4 E 0924585	10/94 M 4 E 0924585	-	-
Cable NSHTÖU-J 36 x 2,5 mm ²		Ø 40 mm		Weight: 2,20 kg/m	
13	LTM 6/12 N 36 P25-	6/36 M 6 D 0924587	6/36 M 6 D 0924587	6/36 M 6 D 0924587	6/25 M 4 E 0924588
29	LTM 6/15 N 36 P25-	6/51 M 6 D 0924589	6/51 M 6 D 0924589	6/32 M 4 E 0924591	-
40	LTM 8/18 N 36 P25-	6/60 M 6 D 0924593	6/60 M 6 D 0924593	6/45 M 4 E 0924594	-
63	LTM 8/21 N 36 P25-	6/51 M 4 E 0924596	6/51 M 4 E 0924596	6/36 M 3 E 0924597	-
73	LTM 12/25 N 36 P25-	8/57 M 4 E 0924599	8/57 M 4 E 0924599	8/57 M 4 E 0924599	-
112	LTM 15/30 N 36 P25-	10/84 M 4 E 0924602	10/84 M 4 E 0924602	10/84 M 4 E 0924602	-
131	LTM 12/30 N 36 P25-	10/84 M 4 E 0924604	10/84 M 4 E 0924604	-	-
160	LTM 15/34 N 36 P25-	10/105 M 4 E 0924606	10/105 M 4 E 0924606	-	-

REEL DIMENSINAL DATA for selection charts page 37-40

Monospiral wrap, shaft gear

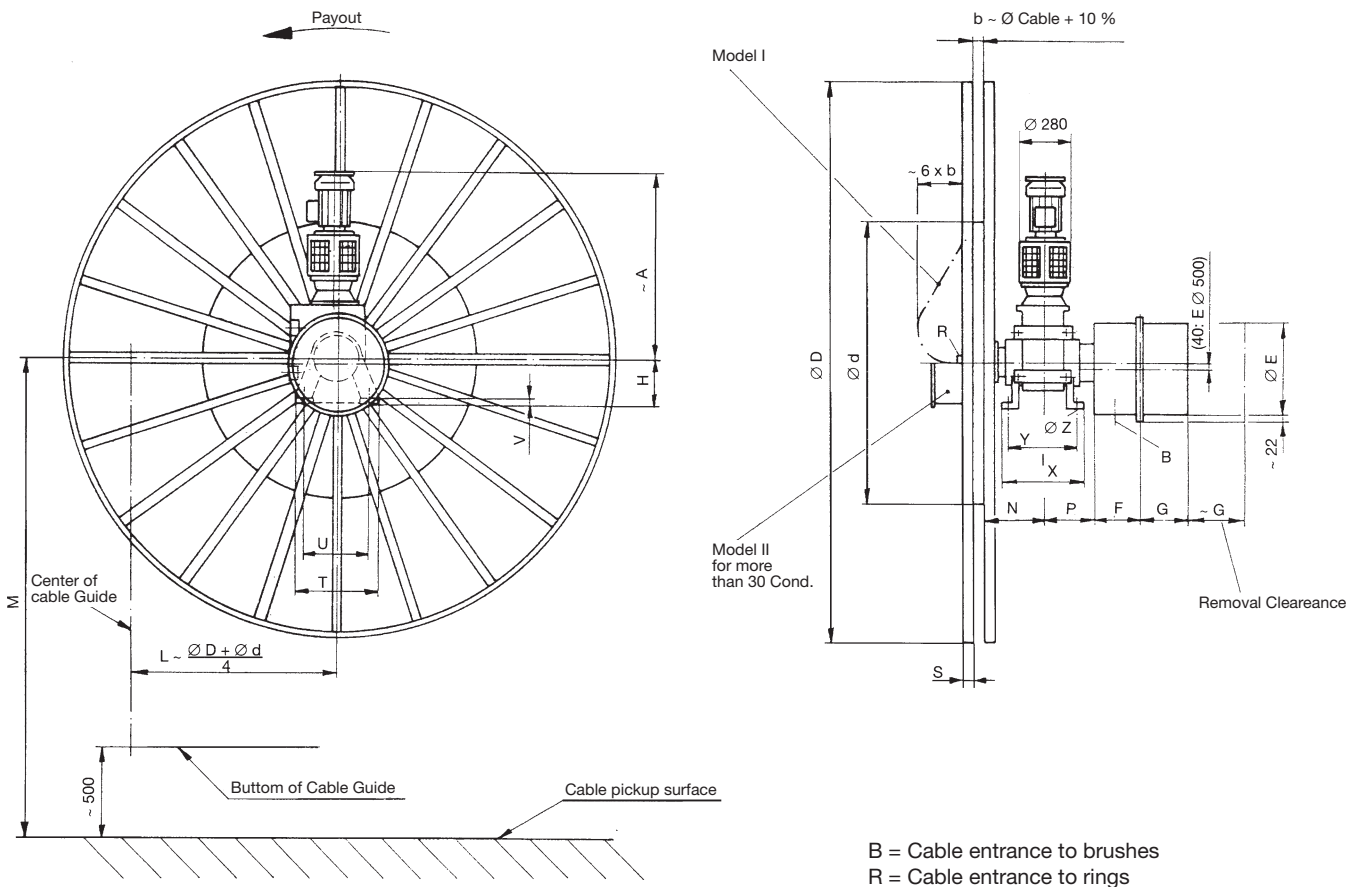

B = Cable entrance to brushes
R = Cable entrance to rings

Reel Type	A	Ø d	Ø D	H	M	N	P	s	T	U	V	X	Y	Ø Z	~ kg
LTM 6/12 N ... - 6	780	600	1200	140	1500*	229	161	20	250	210	20	250	220	13	200
- 8	810			175		255	187		300	240	25	300	260	17	240
LTM 6/15 N ... - 6	780	600	1500	140	1500*	229	161	20	250	210	20	250	220	13	210
- 8	810			175		255	187		300	240	25	300	260	17	250
LTM 8/18 N ... - 6	780	800	1800	140	1500*	229	161	30	250	210	20	250	220	13	230
- 8	810			175		255	187		300	240	25	300	260	17	270
LTM 8/21 N ... - 6	780	800	2100	140	2000*	229	161	40	250	210	20	250	220	13	265
- 8	810			175		255	187		300	240	25	300	260	17	325
LTM 12/25 N ... - 8	810	1200	2500	175	2000*	255	187	40	300	240	25	300	260	17	340
- 10	830			210		310	287		380	310	30	355	300	22	420
LTM 12/30 N ... - 8	810			175		255	187		300	240	25	300	260	17	500
- 10	830	1200	3000	210	3300	310	287	60	380	310	30	355	300	22	635
LTM 15/30 N ... - 8	810			175		255	187		300	240	25	300	260	17	435
- 10	830	1500	3000	210	3300	310	287	50	380	310	30	355	300	22	520
LTM 15/34 N ... - 10	830	1500	3400	210	3450	310	287	60	380	310	30	355	300	22	760

All dimensions in mm

* Installation height without using cable guide

Dimension of collector assembly hoods see page 42.



REEL DIMENSIONAL DATA for selection charts pages 37-40

Monospiral wrap, shaft gear

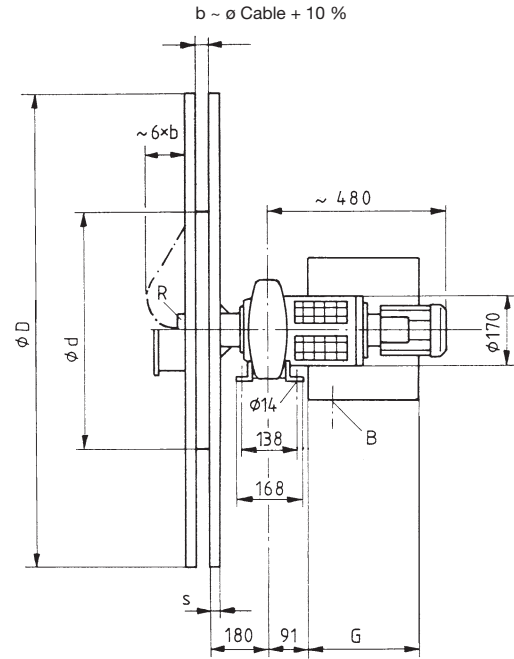
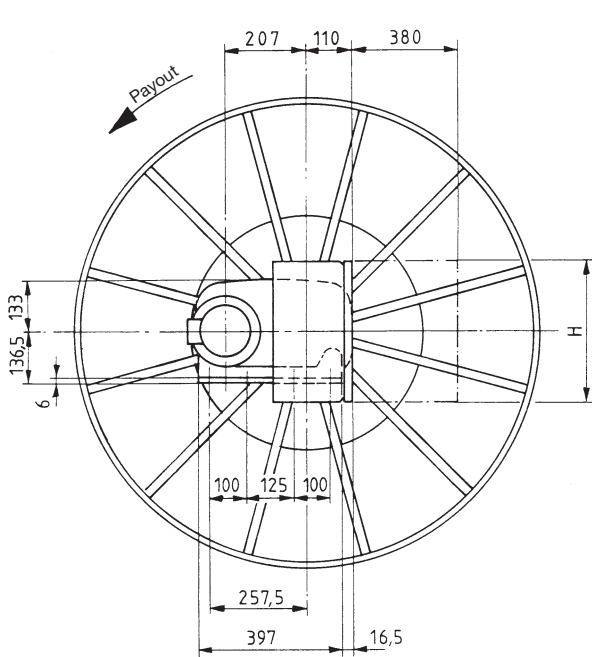

B = Cable entrance to brushes
R = Cable entrance to rings

horizontal payout - installation height max. 1.5 m

Reel Type	Ø d	Ø D	b	N	S	~ kg
LTM 6/12 N 4M60-95/51 MA	600	1200	25	180	20	155

Dimensional data of collector assembly hoods

Assembly hoods p. dwg. page 41

Collector Type Assy	E	F	G
4 M 60	Ø 340	153	153
7 K 60			353
12 K 60			
18 K 60			
24 K 60			553
30 K 60			
36 P 25			353
4 M 150			153
4 M 300	Ø 500	203	203

Assembly hoods p. dwg. page 42

Collector Type Assy	G	H
4 M 60	380	300



Type LTM 11/21 N 4 M 150-6/51 M 4 E



VAHLE MOTOR-DRIVEN REELS

Random wrap, flat gear

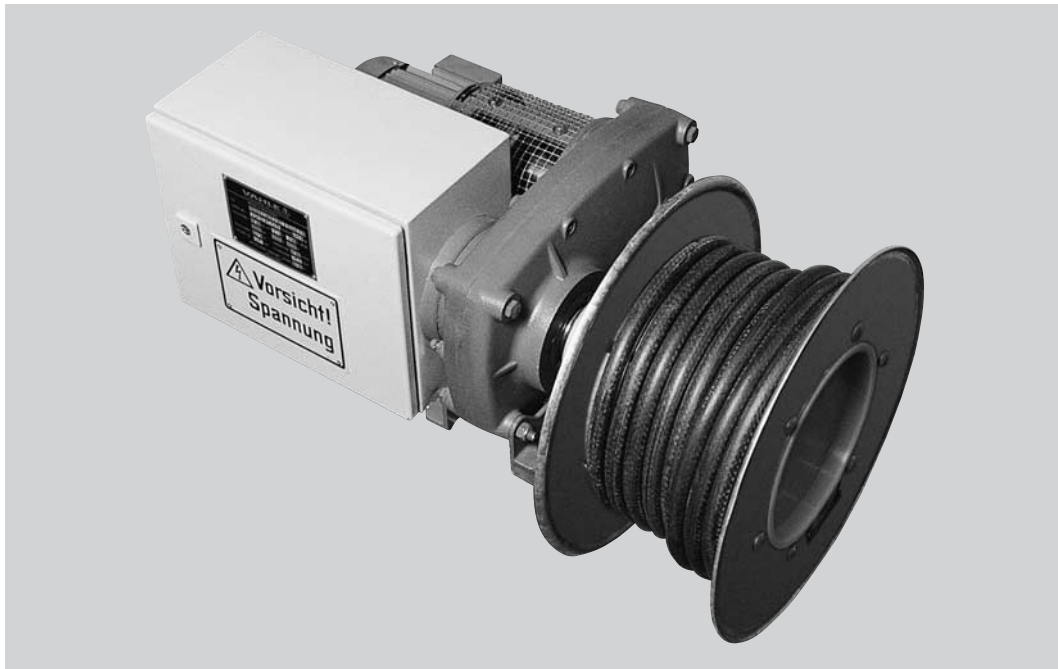

Type LTM 28 N 4 M 60-95/18 M A



Type LTM 38 N 12 K 60-95/30 M A

REEL SELECTION CHART

Random wrap, shaft gear, horizontal payout

Application

1



Cable NSHTÖU-J 4 x 2,5 mm ²		Ø 16,5 mm		Weight: 0,33 kg/m		
active length [m]	LZ*	Reel Type	20 m/min.	40 m/min.	60 m/min.	80 m/min.
32	3	LTM 28 N 4 M60-	95/12 MA 0924396	95/12 MA 0924396	95/12 MA 0924396	95/12 MA 0924396
84	5	LTM 38 N 4 M60-	95/18 MA 0924397	95/18 MA 0924397	95/18 MA 0924397	95/18 MA 0924397
124	5	LTM 50 N 4 M60-	95/24 MA 0924398	95/24 MA 0924398	95/24 MA 0924398	95/24 MA 0924398
Cable NSHTÖU-J 4 x 4 mm ²		Ø 19,5 mm		Weight: 0,47 kg/m		
26	3	LTM 28 N 4 M60-	95/12 MA 0924399	95/12 MA 0924399	95/12 MA 0924399	95/12 MA 0924399
72	5	LTM 38 N 4 M60-	95/18 MA 0924401	95/18 MA 0924401	95/18 MA 0924401	95/18 MA 0924401
108	5	LTM 50 N 4 M60-	95/24 MA 0924402	95/24 MA 0924402	95/24 MA 0924402	95/24 MA 0924402
Cable NSHTÖU-J 4 x 6 mm ²		Ø 21 mm		Weight: 0,60 kg/m		
14	2	LTM 28 N 4 M60-	95/12 MA 0924403	95/12 MA 0924403	95/12 MA 0924403	95/12 MA 0924403
49	4	LTM 38 N 4 M60-	95/18 MA 0924404	95/18 MA 0924404	95/18 MA 0924404	95/18 MA 0924404
100	5	LTM 50 N 4 M60-	95/24 MA 0924405	95/24 MA 0924405	95/24 MA 0924405	95/24 MA 0924405
139	5	LTM 50.1 N 4 M60-	95/27 MA 0924406	95/27 MA 0924406	95/27 MA 0924406	95/25 MA 0924407
Cable NSHTÖU-J 4 x 10 mm ²		Ø 25,5 mm		Weight: 0,95 kg/m		
31	3	LTM 38 N 4 M60-	95/18 MA 0924408	95/18 MA 0924408	95/18 MA 0924408	95/18 MA 0924408
64	4	LTM 50 N 4 M60-	95/24 MA 0924409	95/24 MA 0924409	95/24 MA 0924409	- -
87	4	LTM 50.1 N 4 M60-	95/30 MA 0924411	95/30 MA 0924411	95/30 MA 0924411	6/12 M 6 D 0924412
150	5	LTM 70 N 4 M60-	8/19 M 6 D 0924413	8/19 M 6 D 0924413	8/19 M 6 D 0924413	8/19 M 6 D 0924413
168	5	LTM 80 N 4 M60-	10/19 M 6 D 0924608	10/19 M 6 D 0924608	10/19 M 6 D 0924608	10/19 M 6 D 0924608
Cable NSHTÖU-J 4 x 16 mm ²		Ø 30 mm		Weight: 1,40 kg/m		
23	3	LTM 38 N 4 M150-	95/20 MA 0924414	95/20 MA 0924414	95/20 MA 0924414	95/19 MA 0924415
50	4	LTM 50 N 4 M150-	95/30 MA 0924416	95/30 MA 0924416	95/30 MA 0924416	6/12 M 6 D 0924417
80	4	LTM 50.1 N 4 M150-	6/15 M 6 D 0924418	6/15 M 6 D 0924418	6/15 M 6 D 0924418	6/15 M 6 D 0924418
140	5	LTM 70 N 4 M150-	8/25 M 6 D 0924419	8/25 M 6 D 0924419	8/25 M 6 D 0924419	8/25 M 6 D 0924419
156	5	LTM 80 N 4 M150-	10/26 M 6 D 0924609	10/26 M 6 D 0924609	10/26 M 6 D 0924609	10/29 M 6 D 0924609

* LZ = No. of cable layers



REEL SELECTION CHART

Random wrap, shaft gear, horizontal payout

Application

1

Cable NSHTÖU-J 4 x 25 mm ²		Ø 35 mm		Weight: 1,90 kg/m			
active length [m]	LZ*	Reel Type	20 m/min.	40 m/min.	60 m/min.	80 m/min.	
30	3	LTM 50 N 4 M150-	95/32 MA 0924421	95/32 MA 0924421	95/32 MA 0924421	6/12 M 6 D 0924422	
47	3	LTM 50.1 N 4 M150-	95/42 MA 0924423	95/42 MA 0924423	6/15 M 6 D 0924424	6/15 M 6 D 0924424	
118	5	LTM 70 N 4 M150-	8/28 M 6 D 0924425	8/28 M 6 D 0924425	8/28 M 6 D 0924425	8/28 M 6 D 0924425	
130	5	LTM 80 N 4 M150-	10/31 M 6 D 0924611	10/31 M 6 D 0924611	10/31 M 6 D 0924611	10/31 M 6 D 0924611	
Cable NSHTÖU-J 4 x 35 mm ²		Ø 39,5 mm		Weight: 2,60 kg/m			
42	3	LTM 50.1 N 4 M150-	6/22 M 6 D 0924426	6/22 M 6 D 0924426	6/22 M 6 D 0924426	6/22 M 6 D 0924426	
80	4	LTM 70 N 4 M150-	8/32 M 6 D 0924427	8/32 M 6 D 0924427	8/32 M 6 D 0924427	8/22 M 4 E 0924428	
118	5	LTM 80 N 4 M150-	10/38 M 6 D 0924612	10/38 M 6 D 0924612	10/38 M 6 D 0924612	10/26 M 4 E 0924613	
Cable NSHTÖU-J 7 x 1,5 mm ²		Ø 19 mm		Weight: 0,43 kg/m			
26	3	LTM 28 N 7 K60-	95/12 MA 0924614	95/12 MA 0924614	95/12 MA 0924614	95/12 MA 0924614	
72	5	LTM 38 N 7 K60-	95/19 MA 0924615	95/19 MA 0924615	95/19 MA 0924615	95/19 MA 0924615	
107	5	LTM 50 N 7 K60-	95/24 MA 0924616	95/24 MA 0924616	95/24 MA 0924616	95/24 MA 0924616	
154	5	LTM 50.1 N 7 K60-	95/24 MA 0924617	95/24 MA 0924617	95/24 MA 0924617	95/24 MA 0924617	
Cable NSHTÖU-J 12 x 1,5 mm ²		Ø 22 mm		Weight: 0,60 kg/m			
14	2	LTM 28 N 12 K60-	95/13 MA 0924618	95/13 MA 0924618	95/13 MA 0924618	95/13 MA 0924618	
49	4	LTM 38 N 12 K60-	95/19 MA 0924619	95/19 MA 0924619	95/19 MA 0924619	95/19 MA 0924619	
92	5	LTM 50 N 12 K60-	95/27 MA 0924621	95/27 MA 0924621	95/27 MA 0924621	6/10 M 6 D 0924622	
139	5	LTM 50.1 N 12 K60-	95/27 MA 0924623	95/27 MA 0924623	95/27 MA 0924623	6/10 M 6 D 0924624	
Cable NSHTÖU-J 30 x 2,5 mm ²		Ø 30,5 mm		Weight: 1,20 kg/m			
24	3	LTM 38 N 24 K60-	95/30 MA 0924625	95/30 MA 0924625	6/12 M 6 D 0924626	6/12 M 6 D 0924626	
50	4	LTM 50 N 24 K60-	95/38 MA 0924627	95/38 MA 0924627	6/15 M 6 D 0924628	6/15 M 6 D 0924628	
74	4	LTM 50.1 N 24 K60-	95/38 MA 0924629	95/38 MA 0924629	6/15 M 6 D 0924631	6/15 M 6 D 0924631	
128	5	LTM 70 N 24 K60-	8/22 M 6 D 0924632	8/22 M 6 D 0924632	8/22 M 6 D 0924632	8/22 M 6 D 0924632	
143	5	LTM 80 N 24 K60-	10/23 M 6 D 0924633	10/23 M 6 D 0924633	10/23 M 6 D 0924633	10/23 M 6 D 0924633	

* LZ = No. of cable layers

REEL SELECTION CHART

Random wrap, shaft gear, horizontal payout

Application

1



Cable NSHTÖU-J 7 x 2,5 mm ²		Ø 21,5 mm		Weight: 0,56 kg/m		
active length [m]	LZ*	Reel Type	20 m/min.	40 m/min.	60 m/min.	80 m/min.
14	2	LTM 28 N 7 K60-	95/12 MA 0924634	95/12 MA 0924634	95/12 MA 0924634	95/12 MA 0924634
49	4	LTM 38 N 7 K60-	95/19 MA 0924635	95/19 MA 0924635	95/19 MA 0924635	95/19 MA 0924635
92	5	LTM 50 N 7 K60-	95/27 MA 0924636	95/27 MA 0924636	95/27 MA 0924636	6/10 M 6 D 0924637
139	5	LTM 50.1 N 7 K60-	95/27 MA 0924638	95/27 MA 0924638	95/27 MA 0924638	6/10 M 6 D 0924639
Cable NSHTÖU-J 12 x 2,5 mm ²		Ø 25,5 mm		Weight: 0,85 kg/m		
31	3	LTM 38 N 12 K60-	95/20 MA 0924641	95/20 MA 0924641	95/20 MA 0924641	6/10 M 6 D 0924642
64	4	LTM 50 N 12 K60-	95/30 MA 0924643	95/30 MA 0924643	95/30 MA 0924643	6/12 M 6 D 0924644
87	4	LTM 50.1 N 12 K60-	95/30 MA 0924645	95/30 MA 0924645	95/30 MA 0924645	6/12 M 6 D 0924646
150	5	LTM 70 N 12 K60-	8/16 M 6 D 0924647	8/16 M 6 D 0924647	8/16 M 6 D 0924647	8/16 M 6 D 0924647
168	5	LTM 80 N 12 K60-	10/19 M 6 D 0924648	10/19 M 6 D 0924648	10/19 M 6 D 0924648	10/19 M 6 D 0924648
Cable NSHTÖU-J 18 x 2,5 mm ²		Ø 29,5 mm		Weight: 1,20 kg/m		
27	3	LTM 38 N 18 K60-	95/27 MA 0924649	95/27 MA 0924649	6/10 M 6 D 0924651	6/10 M 6 D 0924651
58	4	LTM 50 N 18 K60-	95/38 MA 0924652	95/38 MA 0924652	6/15 M 6 D 0924653	6/15 M 6 D 0924653
81	4	LTM 50.1 N 18 K60-	95/38 MA 0924654	95/38 MA 0924654	6/15 M 6 D 0924655	6/15 M 6 D 0924655
141	5	LTM 70 N 18 K60-	8/22 M 6 D 0924656	8/22 M 6 D 0924656	8/22 M 6 D 0924656	8/22 M 6 D 0924656
156	5	LTM 80 N 18 K60-	10/23 M 6 D 0924657	10/23 M 6 D 0924657	10/23 M 6 D 0924657	10/23 M 6 D 0924657
Cable NSHTÖU-J 24 x 2,5 mm ²		Ø 34,5 mm		Weight: 1,65 kg/m		
30	3	LTM 50 N 24 K60-	95/42 MA 0924658	95/42 MA 0924658	6/17 M 6 D 0924659	6/17 M 6 D 0924659
47	3	LTM 50.1 N 24 K60-	95/42 MA 0924661	95/42 MA 0924661	6/17 M 6 D 0924662	6/17 M 6 D 0924662
118	5	LTM 70 N 24 K60-	8/28 M 6 D 0924663	8/28 M 6 D 0924663	8/28 M 6 D 0924663	8/28 M 6 D 0924663
131	5	LTM 80 N 24 K60-	10/31 M 6 D 0924664	10/31 M 6 D 0924664	10/31 M 6 D 0924664	10/31 M 6 D 0924664
Cable NSHTÖU-J 30 x 2,5 mm ²		Ø 36,5 mm		Weight: 1,90 kg/m		
30	3	LTM 50 N 30 K60-	95/47 MA 0924665	95/47 MA 0924665	6/17 M 6 D 0924666	6/17 M 6 D 0924666
47	3	LTM 50.1 N 30 K60-	95/47 MA 0924667	95/47 MA 0924667	6/17 M 6 D 0924668	6/17 M 6 D 0924668
118	5	LTM 70 N 30 K60-	8/28 M 6 D 0924669	8/28 M 6 D 0924669	8/28 M 6 D 0924669	8/28 M 6 D 0924669
128	5	LTM 80 N 30 K60-	10/31 M 6 D 0924671	10/31 M 6 D 0924671	10/31 M 6 D 0924671	10/31 M 6 D 0924671

* LZ = No. of cable layers



REEL SELECTION CHART

Random wrap, shaft gear, vertical lift

Application

8

Cable NSHTÖU-J 4 x 2,5 mm ²		Ø 16,5 mm		Weight: 0,33 kg/m			
active length [m]	LZ*	Reel Type	12 m/min.	20 m/min.	30 m/min.	40 m/min.	60 m/min.
10	1,2	LTM 28 S 4 M60-	95/12 MA 0924672	95/12 MA 0924672	95/12 MA 0924672	95/12 MA 0924672	95/12 MA 0924672
20	1,6	LTM 38 S 4 M60-	95/20 MA 0924673	95/20 MA 0924673	95/20 MA 0924673	95/20 MA 0924673	95/20 MA 0924673
Cable NSHTÖU-J 4 x 4 mm ²		Ø 19,5 mm		Weight: 0,47 kg/m			
10	1,4	LTM 28 S 4 M60-	95/13 MA 0924674	95/13 MA 0924674	95/13 MA 0924674	95/13 MA 0924674	95/13 MA 0924674
20	1,8	LTM 38 S 4 M60-	95/24 MA 0924675	95/24 MA 0924675	95/24 MA 0924675	95/24 MA 0924675	95/24 MA 0924675
30	2,5	LTM 38 S 4 M60-	95/30 MA 0924676	95/30 MA 0924676	95/30 MA 0924676	95/30 MA 0924676	6/12 M 6 D 0924677
Cable NSHTÖU-J 4 x 6 mm ²		Ø 21 mm		Weight: 0,60 kg/m			
10	1,6	LTM 28 S 4 M60-	95/15 MA 0924678	95/15 MA 0924678	95/15 MA 0924678	95/15 MA 0924678	95/15 MA 0924678
20	1,9	LTM 38 S 4 M60-	95/27 MA 0924679	95/27 MA 0924679	95/27 MA 0924679	95/27 MA 0924679	6/12 M 6 D 0924681
30	2,7	LTM 38 S 4 M60-	95/35 MA 0924682	95/35 MA 0924682	95/35 MA 0924682	95/35 MA 0924682	6/15 M 6 D 0924683
Cable NSHTÖU-J 4 x 10 mm ²		Ø 25,5 mm		Weight: 0,95 kg/m			
10	1,3	LTM 38 S 4 M60-	95/27 MA 0924684	95/27 MA 0924684	95/27 MA 0924684	95/27 MA 0924684	6/12 M 6 D 0924685
20	2,1	LTM 38 S 4 M60-	95/38 MA 0924686	95/38 MA 0924686	95/38 MA 0924686	95/38 MA 0924686	6/15 M 6 D 0924689
30	2,9	LTM 38 S 4 M60-	95/51 MA 0924691	95/51 MA 0924691	95/51 MA 0924691	6/20 M 6 D 0924692	6/20 M 6 D 0924692
Cable NSHTÖU-J 4 x 16 mm ²		Ø 30 mm		Weight: 1,40 kg/m			
10	1,6	LTM 38 S 4 M150-	95/35 MA 0924693	95/35 MA 0924693	95/35 MA 0924693	95/35 MA 0924693	6/15 M 6 D 0924694
20	2,6	LTM 38 S 4 M150-	95/51 MA 0924695	95/51 MA 0924695	95/51 MA 0924695	6/20 M 6 D 0924696	6/20 M 6 D 0924696
30	2,7	LTM 50 S 4 M150-	6/36 M 6 D 0924697	6/36 M 6 D 0924697	6/36 M 6 D 0924697	6/36 M 6 D 0924697	6/25 M 4 E 0924698
Cable NSHTÖU-J 4 x 25 mm ²		Ø 35 mm		Weight: 1,90 kg/m			
10	1,3	LTM 50 S 4 M150-	6/22 M 6 D 0924699	6/22 M 6 D 0924699	6/22 M 6 D 0924699	6/22 M 6 D 0924699	6/22 M 6 D 0924699
20	2,2	LTM 50 S 4 M150-	6/36 M 6 D 0924701	6/36 M 6 D 0924701	6/36 M 6 D 0924701	6/36 M 6 D 0924701	6/25 M 4 E 0924702

* LZ = No. of cable layers

REEL SELECTION CHART

Random wrap, shaft gear, vertical lift

Application

8



Cable NSHTÖU-J 12 x 1,5 mm ²			Ø 22 mm			Weight: 0,60 kg/m	
active length [m]	LZ*	Reel Type	12 m/min.	20 m/min.	30 m/min.	40 m/min.	60 m/min.
10	1,5	LTM 28 S 12 K60-	95/17 MA 0924703	95/17 MA 0924703	95/17 MA 0924703	95/17 MA 0924703	95/17 Ma 0924703
20	1,9	LTM 38 S 12 K60-	95/27 MA 0924704	95/27 Ma 0924704	95/27 MA 0924704	95/27 MA 0924704	6/12 M 6 D 0924705
30	2,7	LTM 38 S 12 K60-	95/35 MA 0924706	95/35 MA 0924706	95/35 MA 0924706	95/35 MA 0924706	6/15 M 6 D 0924707
Cable NSHTÖU-J 24 x 1,5 mm ²			Ø 30,5 mm			Weight: 1,20 kg/m	
10	1,6	LTM 38 S 24 K60-	95/35 MA 0924708	95/35 MA 0924708	95/35 MA 0924708	95/35 MA 0924708	6/12 M 6 D 0924709
20	2,6	LTM 38 S 24 K60-	95/51 MA 0924711	95/51 MA 0924711	95/51 MA 0924711	6/20 M 6 D 0924712	6/20 M 6 D 0924712
30	2,7	LTM 50 S 24 K60-	6/32 M 6 D 0924713	6/32 M 6 D 0924713	6/32 M 6 D 0924713	6/32 M 6 D 0924713	6/22 M 4 E 0924714
Cable NSHTÖU-J 7 x 2,5 mm ²			Ø 21,5 mm			Weight: 0,56 kg/m	
10	1,5	LTM 28 S 7 K60-	95/16 MA 0924715	95/16 MA 0924715	95/16 MA 0924715	95/16 MA 0924715	95/16 MA 0924715
20	1,9	LTM 38 S 7 K60-	95/27 MA 0924716	95/27 MA 0924716	95/27 MA 0924716	95/27 MA 0924716	6/10 M 6 D 0924717
30	2,7	LTM 38 S 7 K60-	95/35 MA 0924718	95/35 MA 0924718	95/35 MA 0924718	95/35 MA 0924718	6/12 M 6 D 0924719
Cable NSHTÖU-J 12 x 2,5 mm ²			Ø 25,5 mm			Weight: 0,85 kg/m	
10	1,3	LTM 38 S 12 K60-	95/27 MA 0924721	95/27 MA 0924721	95/27 MA 0924721	95/27 MA 0924721	6/10 M 6 D 0924722
20	2,1	LTM 38 S 12 K60-	95/38 MA 0924723	95/38 MA 0924723	95/38 MA 0924723	95/38 MA 0924723	6/15 M 6 D 0924724
30	2,9	LTM 38 S 12 K60-	95/47 MA 0924725	95/47 MA 0924725	95/47 MA 0924725	6/17 M 6 D 0924726	6/17 M 6 D 0924726
Cable NSHTÖU-J 18 x 2,5 mm ²			Ø 29,5 mm			Weight: 1,20 kg/m	
10	1,4	LTM 38 S 18 K60-	95/35 MA 0924727	95/35 MA 0924727	95/35 MA 0924727	95/35 MA 0924727	6/15 M 6 D 0924728
20	2,3	LTM 38 S 18 K60-	95/47 MA 0924729	95/47 MA 0924729	95/47 MA 0924729	6/17 M 6 D 0924731	6/17 M 6 D 0924731
30	2,4	LTM 50 S 18 K60-	6/32 M 6 D 0924732	6/32 M 6 D 0924732	6/32 M 6 D 0924732	6/32 M 6 D 0924732	6/22 M 4 E 0924733
Cable NSHTÖU-J 24 x 2,5 mm ²			Ø 34,5 mm			Weight: 1,65 kg/m	
10	1,3	LTM 50 S 24 K60-	6/22 M 6 D 0924734	6/22 M 6 D 0924734	6/22 M 6 D 0924734	6/22 M 6 D 0924734	6/22 M 6 D 0924734
20	2,2	LTM 50 S 24 K60-	6/32 M 6 D 0924735	6/32 M 6 D 0924735	6/32 M 6 D 0924735	6/32 M 6 D 0924735	6/22 M 4 E 0924736
Cable NSHTÖU-J 30 x 2,5 mm ²			Ø 36,5 mm			Weight: 1,90 kg/m	
10	1,3	LTM 50 S 30 K60-	6/25 M 6 D 0924737	6/25 M 6 D 0924737	6/25 M 6 D 0924737	6/25 M 6 D 0924737	6/17 M 4 E 0924738
20	2,2	LTM 50.1 S 30 K60-	6/36 M 6 D 0924739	6/36 M 6 D 0924739	6/36 M 6 D 0924739	6/36 M 6 D 0924739	6/25 M 4 E 0924741

* LZ = No. of cable layers



REEL DIMENSIONAL DATA for selection charts pages 45-49

Random wrap, shaft gear

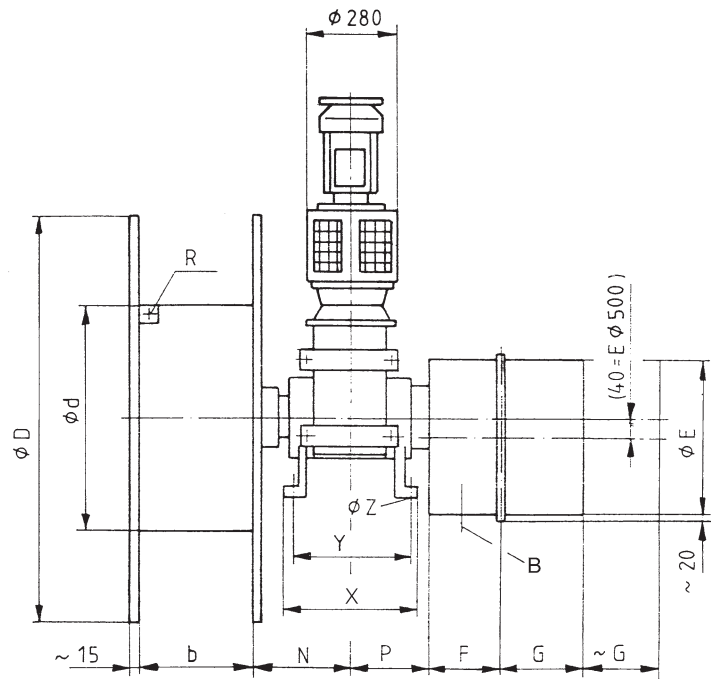
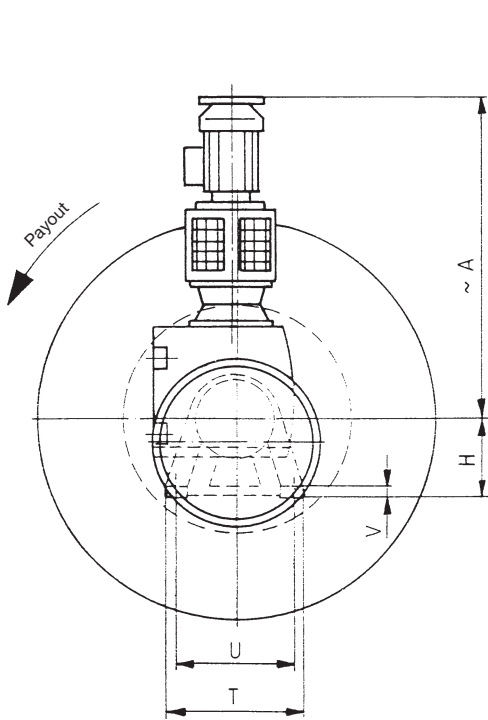

B = Cable entrance to brushes
R = Cable entrance to rings

Application 1

horizontal payout - installation height max. 1.5 m

Reel Type	A	b	ϕd	ϕD	H	N	P	T	U	V	X	Y	ϕZ	= kg
LTM 38 N... - 6	780	220	380	650	140	232	161	250	210	20	250	220	13	180
LTM 50 N... - 6	780	250	500	800	140	232	161	250	210	20	250	220	13	205
LTM 50.1 N... - 6	780	350	500	900	140	232	161	250	210	20	250	220	13	230
LTM 70 N... - 8	810	350	700	1200	175	264	187	300	240	25	300	260	17	265
LTM 80 N... - 10	830	350	800	1400	210	319	287	380	310	30	355	300	22	420

Application 8

vertical lift

Reel Type	A	b	ϕd	ϕD	H	N	P	T	U	V	X	Y	ϕZ	= kg
LTM 38 S... - 6	780	220	380	650	140	232	161	250	210	20	250	220	13	180
LTM 50 S... - 6	780	250	500	800	140	232	161	250	210	20	250	220	13	205
LTM 50.1 S... - 6	780	350	500	900	140	232	161	250	210	20	250	220	13	230

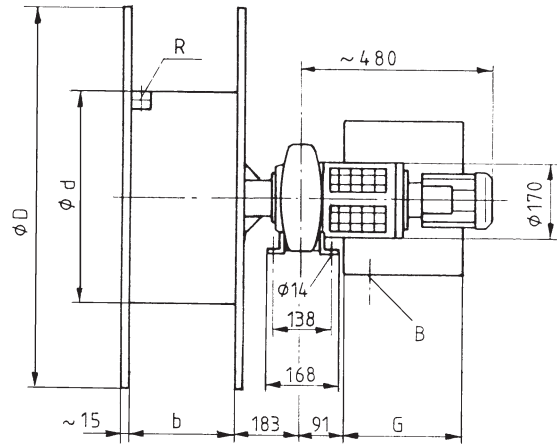
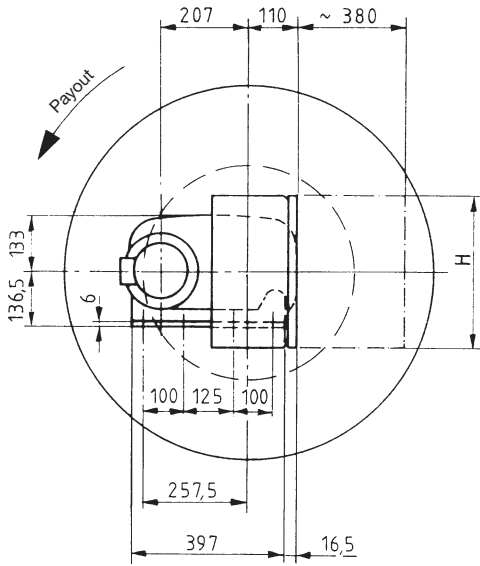

B = Cable entrance to brushes
R = Cable entrance to rings

Applications 1 8

Reel Type	b	Ø d	Ø D	~ kg
LTM 28 N ... -95/ ... MA S	200	280	450	125
LTM 38 N ... -95/ ... MA S	220	380	650	150
LTM 50 N ... -95/ ... MA	250	500	800	175
LTM 50.1 N ... -95/ ... MA	350	500	900	200

Dimensional data of collector assembly hoods

Assembly hoods p. dwg. page 50

Collector Assy Type	E	F	G
4 M 60	Ø 340	153	153
7 K 60			353
12 K 60			
18 K 60			
24 K 60			
30 K 60			353
36 P 25			
4 M150	Ø 500	203	153
4 M300			203

Assembly hoods p. dwg. above

Collector Assy Type	G	H
4 M 60	380	300
7 K 60		
12 K 60		
18 K 60	600	380
24 K 60		
30 K 60	700	
36 P 25	600	
4 M150	300	



WIRING DIAGRAMS

for cable reels with magnet coupling series

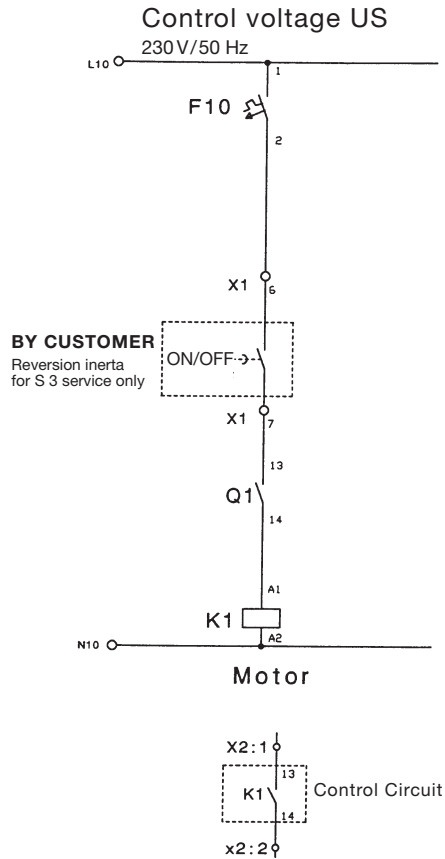
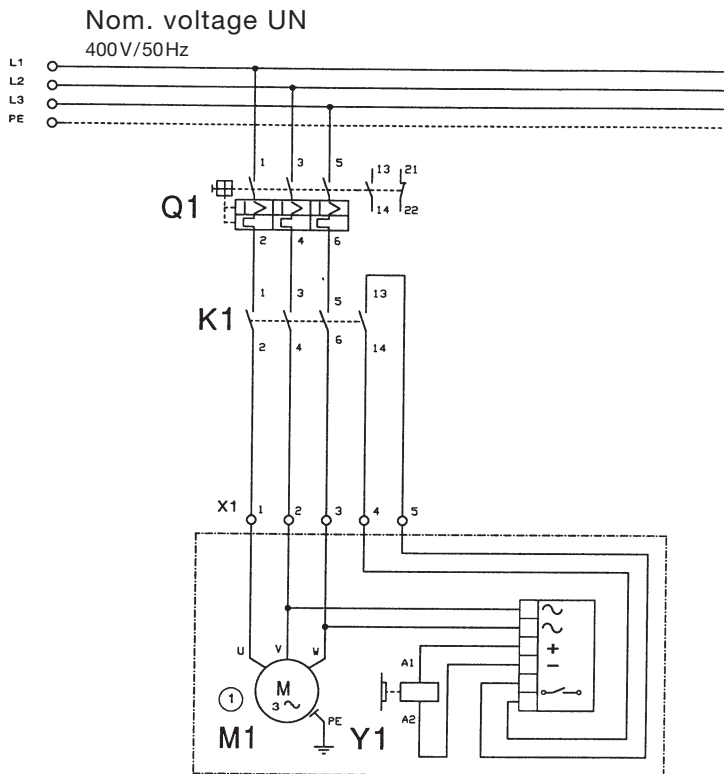

VAHLE's supply includes ① ○ ○ only. Further outfit on special order.

Motor
star-connected
(e. g.: supply voltage 400 V)
(Motor 230/400 V)

Motor
delta-connected
(e. g.: supply voltage 400 V)
(Motor 400/690 V)

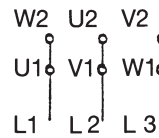
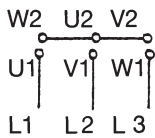

Motor size	kW	n_L [min. ⁻¹] RPM under load	Md [Nm] Torque Moment	DF [%]	UT [°C] Oper. Temperature	U_N [V] Nom. Voltage	F_N [Hz] Nom. Frequency	I_N [A] Nom. Amperage	cos. φ
M E	1,5	1405	10	100	40	400	50	3,5	0.82
M D	1,1	1410	7,5					2,65	0.81
M A	0,37	1375	2,5					1,06	0.76



Guide roller assembly
monospiral wrap
two-way payout
for up to 1000 Volt applications
 More than 1000 Volt ratings require
 $r_{min.} = 15 \text{ times cable OD}$

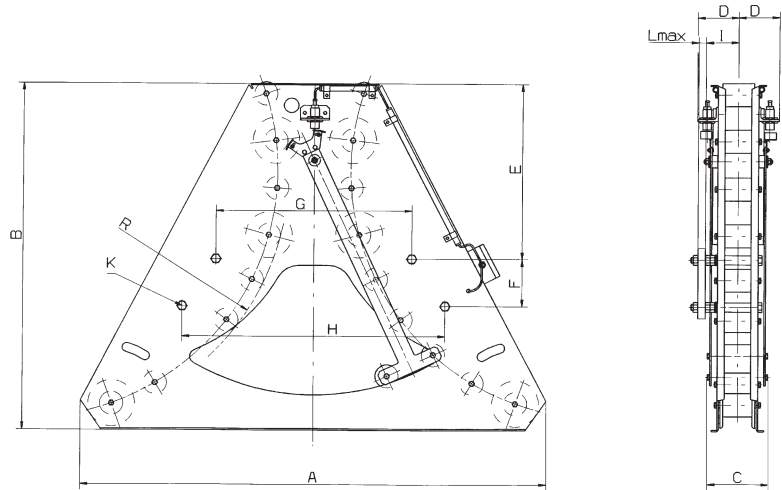

Assy without Pendulum

Type	max. cable. Ø	A	B	C	D	E	F	G	H	I	K	R	≈ kg	Cat.-No.
R 6	55	1140	860	145	–	360	125	430	598	92,5	M 16	600	85	0 924 994
R 9	75	1595	1200	180	–	606	164	670	900	111	M 20	900	150	0 924 995
R 12	83	2100	1660	210	–	560	500	740	1200	111	M 20	1200	250	0 924 996

Assy with Pendulum

for torque moment regulation at cable anchor position (midpoint) and/or for slack cable control.

Type	max. cable. Ø	A	B	C	D	E	F	G	H	I	K	R	≈ kg	Cat.-No. c/w pos. switch	Cat.-No. w/o pos. switch
R 6	55	1140	860	175	123	360	125	4305	598	92,5	M 16	600	90	0 926 575	0 924 997
R 9	75	1595	1200	210	140	606	164	670	900	111	M 20	900	155	0 925 072	0 924 998
R 12	83	2100	1660	210	140	560	500	740	1200	111	M 20	1200	255	0 926 572	0 924 999

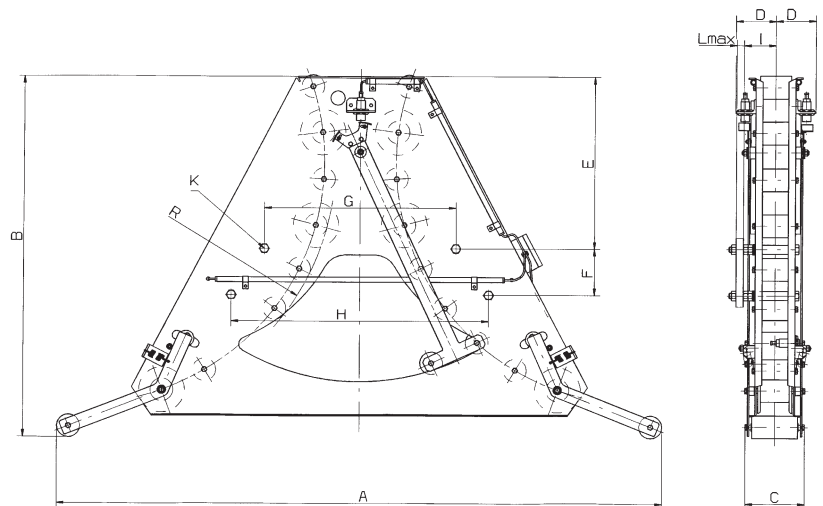

Assy with Tension Control

Type	max. cable Ø	A	B	C	D	E	F	G	H	I	K	R	≈ kg	Cat.-No. c/w pos. switch	Cat.-No. w/o pos. switch
RZ 6	55	1700	930	185	123	360	125	430	598	92,5	M 16	600	95	0 926 576	0 924 742
RZ 9	75	2175	1240	220	140	606	164	670	900	111	M 20	900	160	0 925 073	0 925 002
RZ 12	83	2600	1710	220	140	560	500	740	1200	111	M 20	1200	260	0 926 573	0 925 003



ACCESSORIES

Double sheave guides

Double sheave guides

used for up to 1000 Volt applications
two-way payout

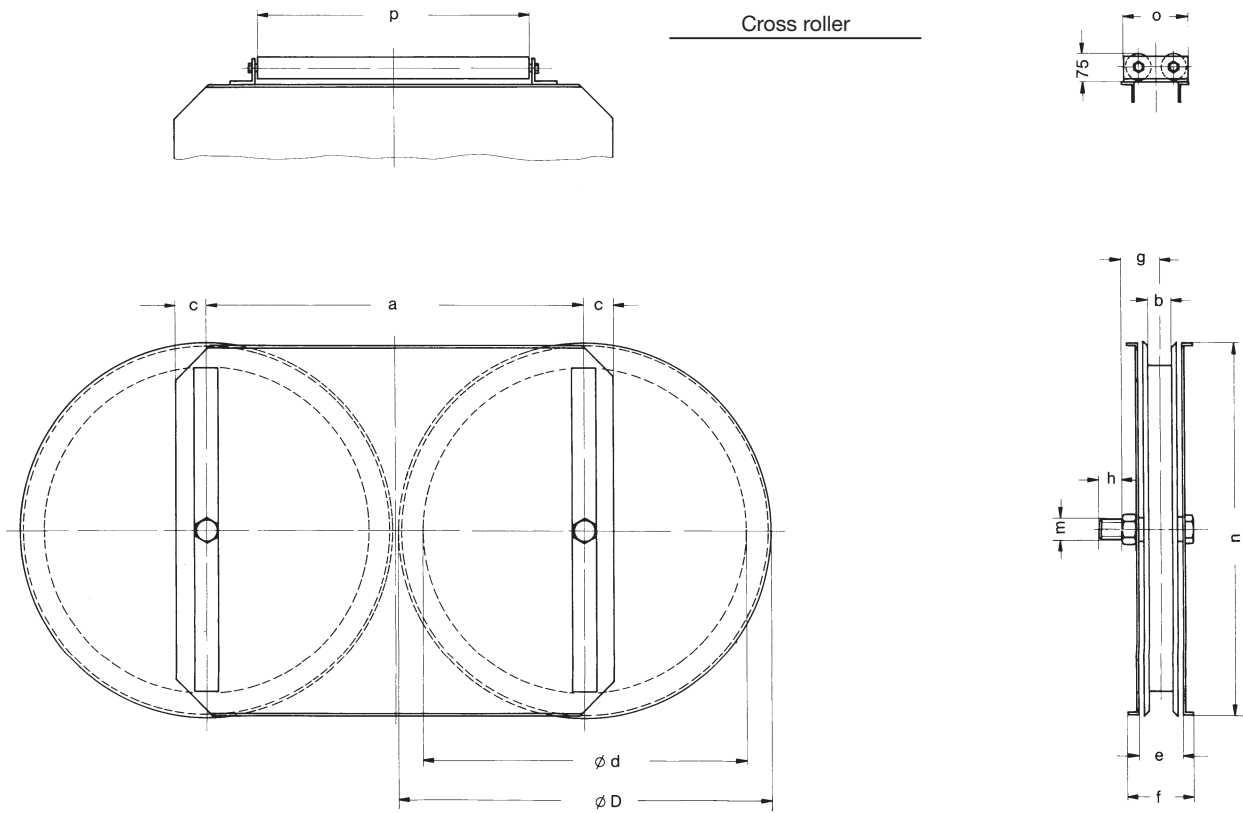

Assy without cross roller

Type	Cat.-No.	max. cable. Ø	a	b	c	Ø d	Ø D	e	f	g	h	m	n	o	P	≈kg
SU - 1	0901635	23	455	70	33	350	450	114	170	85	50	M 24	445	180	315	34
SU - 2	0901636	33,5	655		48	503	650						640		400	90
SU - 3	0901637	44	785		80	663	780						770		500	120
SU - 4	0901638	52	905		75	783	900						890		600	130
SU - 5	0901639	60	1105	80	73	900	1100	134	192	103	62	M 30	1090	210	800	220

Assy with cross roller

Type	Cat.-No.	max. cable. Ø	a	b	c	Ø d	Ø D	e	f	g	h	m	n	o	P	≈kg
SU - R1	0901630	23	455	70	33	350	450	114	170	85	50	M 24	445	180	315	34
SU - R2	0901631	33,5	655		48	503	650						640		400	96
SU - R3	0901632	44	785		80	663	780						770		500	126
SU - R4	0901633	52	905		75	783	900						890		600	136
SU - R5	0901634	60	1105	80	73	900	1100	134	192	103	62	M 30	1090	210	800	226

Feed-point Funnels used applications up to 1000 Volt · two-way payout.
All usual travel speeds and frequency passing over midpoint.

Type	ETZ 3	ETZ 4	ETZ 5	ETZ 7	ETZ 9	ETZ 12
Cat.-No.	0921380	0921390	0921400	0921410	0921720	0926651
max. cable Ø	34	50	62	80 ~ 60*	90 ~ 70*	~ 90*
a	650	900	1220	1760	2070	2660
b	530	700	900	1200	1475	1930
c	106	146	208	208	216	60
d / r	275	400	500	700	900	1200
e	14	18			22	22
f	40			200	125	150
g	405	550	780	1080	1325	1780
h	400	740	900	1100	1820	2220
i	200				275	330
k	120	210	180	350	1250	1660
l	300	400	600	800	695	920
m	270	410	480	750	960	1260
n	60	80	100		120	120
~ kg	15	28	52	100	130	200

* allowed for applications of more than 1000 V.

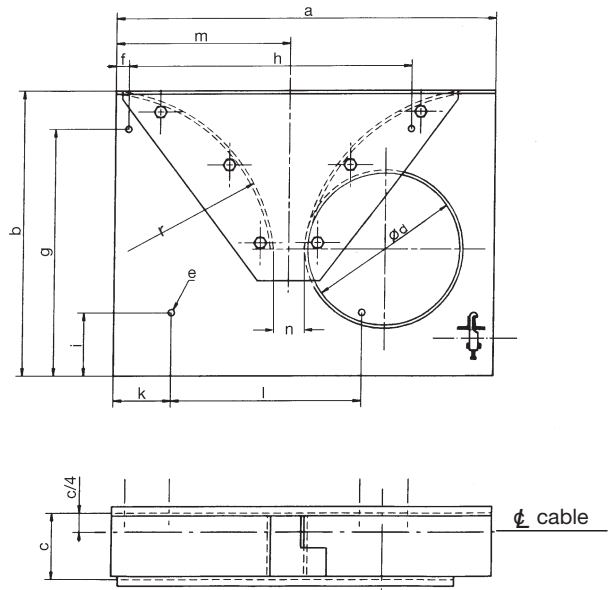

Terminal box 10 kV

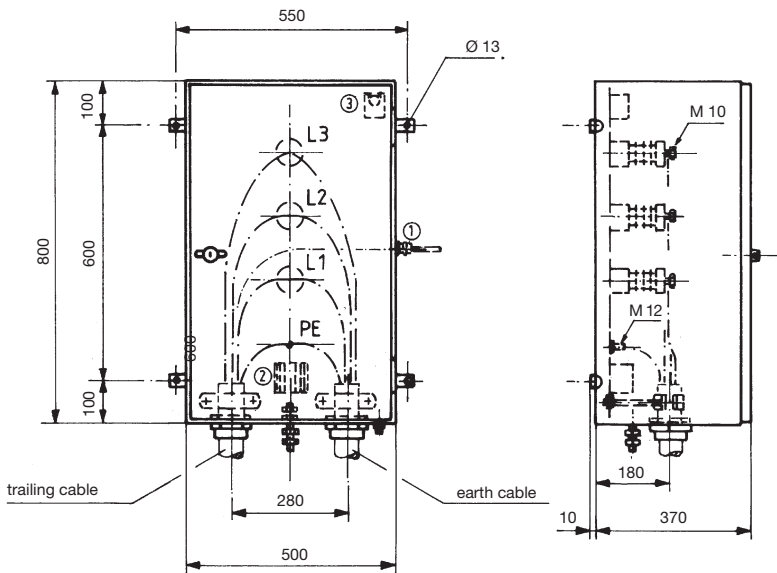

Options: ① fibre optic link (LWL)
②, ③ heating

Type	Cat.-No.
Terminal box 10 kV	926653
Terminal box with LWL-connection	926654
Terminal box with heating	926655
Terminal box with LWL-connection and heating	926656



ACCESSORIES

Cable grips Anchor clamps Support rollers

Wire mesh strain relief grips, 1250 mm long

Type	Cat.-No.	for cable OD mm	Permissible tension* kg
VLZ 1	0901620	15-20	930
VLZ 2	0901621	20-30	1165
VLZ 3	0901622	30-40	1400
VLZ 4	0901623	40-50	1630

* 3-times safety factor considered

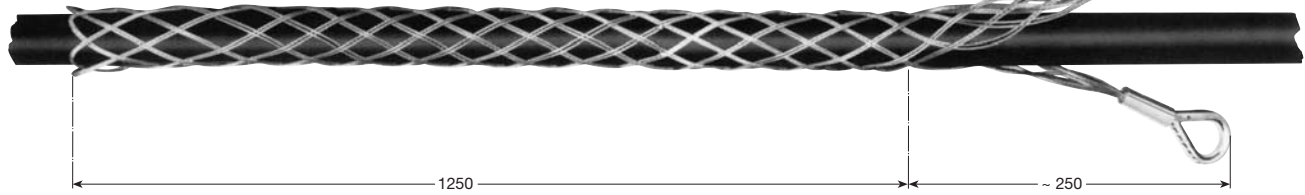

Turnover Anchor Clamps for up to 1000 Volt applications for one- or two-way payout and low travelling speeds

Mainly used in connection with plug & socket service
or when feeding from underneath the cable tray is impossible

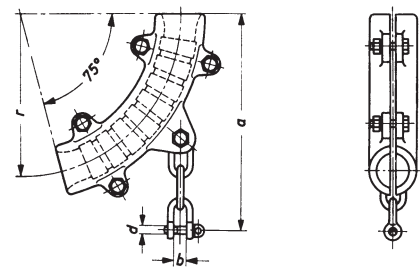

Type	Cat.-No.	for cable OD mm	r	a	d	b	Weight ~ kg
LS 1	0921420	- 21.5	100	205	10	14	1.6
LS 2	0921430	> 21.5 - 28.0	130	225			2.5
LS 3	0921440	> 28.0 - 36.5	170	265	12	17	3.5
LS 4	0921450	> 36.5 - 48.0	220	300			5.5
LS 5	0921460	> 48.0 - 63.0	290	405	16	21	8.5

Cable Support Rollers

Type	Cat.-No.	a	b	c	Weight ~ kg	
TR 80/110 B 200	0924450	110	-	130	2.25	w/o bracket
TR 80/300 B 200	0924460	300	-	320	3.25	
TR 80/500 B 200	0924470	500	-	520	4.50	
TR 80/110 B 200 H	0924480	110	80	130	3.50	c/w bracket
TR 80/300 B 200 H	0924490	300	250	320	5.15	
TR 80/500 B 200 H	0924500	500	400	520	6.90	

Rollers include bolts and washers.

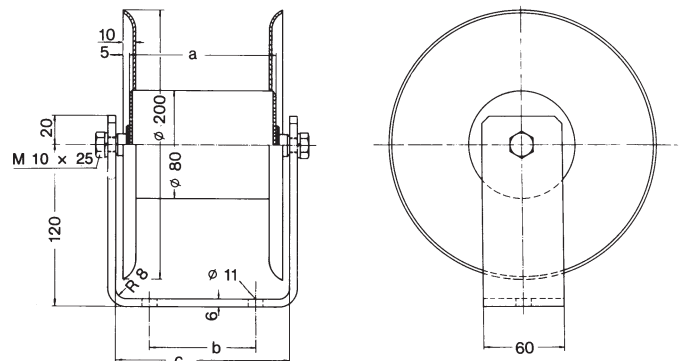

Motor reels - Model LTF - with frequency inverter drive

Careful treatment and long life of cable is achieved by stepless variable torque regulation. All dynamic loads are being considered.

Standard, robust AC motors are used and the frequency inverter is easily programmable. Additional PLC's are not required.

There is a considerable saving of electric energy over conventional drive systems (e.g. torque motors).



Model LTF - with frequency inverter drive, designed for heavy duty and high speed applications.

Motor reels with fibre optic links

Using fibre optic cables on motor reels for continuous data transmission between rotating and stationary system parts requires fibre optic links (usually 6 FO-elements 50/125 or 62,5/125).

This unit guarantees an interruption-free performance to transfer data between computer interfaces, analogous measurements, video signals etc.

A combined fibre optic-copper link is also available.

Recommendations and dimensions to meet your requirements will be furnished on request.

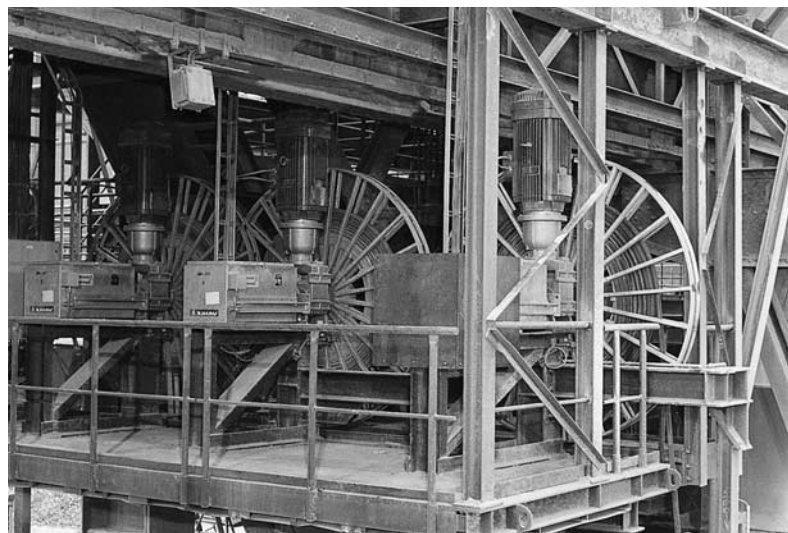

Cable Reels LT in use at a steel mill handling communication cable.



FURTHER MODELS

Model HS - with electro-hydraulic drive for constant torque, designed to power moving equipment operating under severe heavy-duty conditions at high speeds and using heavy-gauge cable.

The hydraulic drive works elastically, thus minimizing cable strain caused by abrupt starting, braking or during flipover point operation.



HS level wind Cable Reel powering Yard Crane incorporates steering mechanism and double sheave cable guide

Model HSB - with electro-hydraulic drive and variable torque for constant cable tension is especially well suited for high-voltage cables and small cross section conductors not tolerating high mechanical stress.

Reels are designed for monospiral wrap with the elastic drive adapting to the spooling diameter.

A taut and slack cable monitoring device is optional.



HSB monospiral wrap Cable Reel used on Container Crane with cable guide and tension control assembly



VAHLE POWERCOM® 485
Motor powered cable reels with VAHLE
POWERCOM® Data Transmission Systems

The interference-free data transmission system works in conjunction with Vahle reels on standard non-screened conductor cables and normal slip-rings.

Our catalog no. 9c has all the details for you.

Model LT/S & HS/S - for level wind, one or multilayer operation to handle extra long cable when there is no room for a monospiral reel.

These wide spools feature a cable steering and distribution mechanism allowing cable payout in a right angle or in parallel to the reel axis.

Mainly meant for extreme heavy working conditions, the LT/S & HS/S kind of drive unit is chosen in accordance to the application.

A taut and slack cable monitoring device is optional.



Foto shows LT/S 150 GH and LT/S G in action



	Catalog No.
Copperhead Conductor Systems	1 a
Battery Charging Systems	1 b
Insulated Conductor Systems U 10	2 a
Insulated Conductor Systems U 20 – U 30 – U 40	2 b
Insulated Conductor Systems U 15 – U 25 – U 35	2 c
Aluminium Enclosed Conductor Systems LSV – LSVG	3 a
Steel Enclosed Conductor Systems SLG – HSL	3 b
Powerail Enclosed Conductor Systems KBSL – KSL – KSLT – KSG	4 a
Powerail Enclosed Conductor Systems VKS – VKL	4 b
Powerail Enclosed Conductor System MKLD – MKLF – MKLS	4 c
Heavy Enclosed Conductor Systems	5
Trolley Wire and Accessories	6
Cable Tenders	7
Cable Carriers for □-tracks	8 a
Cable Carriers for Flatform Cable on I-beams	8 bF
Cable Carriers for Round Cable on I-beams	8 bR
Cable Carriers for ◇-tracks	8 c
Conductor Cables and Fittings	8 L
Spring Operated Cable Reels	9 a
Overload Protection Systems	9 b
VAHLE POWERCOM® – Data Transmission Systems	9 c
CPS – Contactless Power Supply	9 d
SMG – Slotted Microwave Guide	9 e
Position Encoding System	9 f
Motor Powered Cable Reels	10

